

Design of a High Sensitive Non-Faradaic Impedimetric Sensor

Anjan Panneer Selvam*, Krishna M. Vattipalli, and Shalini Prasad

Abstract— an electrochemical approach towards identifying antigen – antibody binding interactions is studied by using a non-faradaic impedimetric sensor fabricated on a printed circuit board (PCB) chip. An electrical methodology for detecting protein interactions at ultra-low concentrations (in the femtogram/mL) regime has been demonstrated. Nanoporous alumina with pore diameter of 200nm and pore depth of 250 nm was used as the signal amplifying medium. Cardiac biomarker, brain natriuretic peptide (BNP) was used as the study marker in characterizing the sensor's sensitivity. A sensitivity of 10 femtogram/mL was determined based on the impedimetric signal response. Sensitivity was determined through Nyquist plot analysis for the non-faradaic interactions of the protein biomolecules. This paper is the first demonstration of clinically relevant limit of detection with the BNP biomarker.

I. INTRODUCTION

Impedance spectroscopy is a powerful method of analyzing the complex electrical resistance of a system and is sensitive to surface phenomena and changes in bulk properties. Thus, it is a valuable method in electrochemical research. In the field of biosensors, it is particularly well-suited to the detection of binding events on the transducer surface. This method has found increasing application in recent years due to advances made in instrumentation.

Besides the detection of bio-recognition processes, it is a valuable tool for characterizing surface modifications, such as those that occur during the immobilization of biomolecules on the transducer. The technique has the inherent potential for label-free detection, which is of special interest in bioanalysis since this circumvents the need to modify biomolecules with fluorescence dyes, enzymes, redox or radioactive labels. Several examples of its application to the detection of DNA, antigens or antibodies have been demonstrated [1-3]. However, an amplification step is often necessary to achieve a defined response with very low analyte concentrations. In this paper we present the application of the impedance spectroscopy technique in conjunction with nanomaterial enabled sensor platforms towards designing highly sensitive biosensors.

The application has been shown for pro NT-BNP, a protein biomarker associated to inflammation with cardiovascular disease[4].

*Corresponding Author.

Anjan Panneer Selvam is with the Bioengineering Department, University of Texas at Dallas, Richardson, TX 75080 USA (214-886-5249; e-mail: axp107120@utdallas.edu).

Krishna M. Vattipalli is with the Bioengineering Department, University of Texas at Dallas, Richardson, TX 75080 USA (e-mail: krishna.vattipalli@utdallas.edu).

Shalini Prasad is with the Bioengineering Department, University of Texas at Dallas, Richardson, TX 75080 USA (e-mail: shalini.prasad@utdallas.edu).

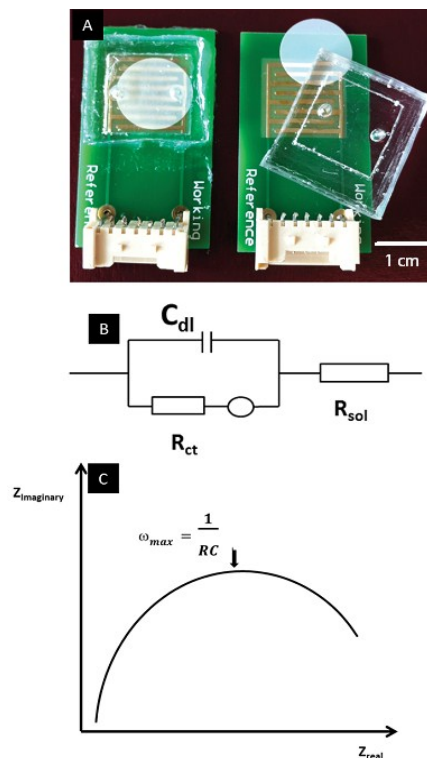

Fig.1. (A) Assembled device configuration with individual components. (B) Randles equivalent circuit for electrode electrolyte interface. C_{dl} is the charge capacitance due to double layer at interface; R_{ct} is the charge transfer resistance due to redox reactions at interface; R_s is the solution resistance due to ion concentration and cell geometry; Z_w is the Warburg impedance due to diffusion from bulk solution to interface. C) Graph showing the correlation between the real and imaginary parts of the impedance. Peak values are concentration (of the analyte under test) dependent.

II. EXPERIMENTAL METHODS

A. Sensor Assembly

The sensor device used that has been implemented for this work has its basis in the hypothesis that size based confinement of protein biomolecules will enhance the efficacy of the protein's association with the receptor [5-7]. The sensor device as shown in Fig. 1(A) comprises of a printed circuit board (PCB) microchip interfaced with nanoporous alumina membrane (pore diameter 200 nm, pore depth 250 nm and lateral diameter 13 mm), resulting in the generation of high density array of nanoscale confined spaces, with metallic base electrodes. Protein capture and association takes place within these confined spaces, which can also be termed as nanowells. The base microchip has an interdigitated electrode design. It comprises of two sets of digits of dimensions (13 mm x 13 mm). These function as the

working and counter electrodes which are in the ratio of 1:2. The impedance is measured over these electrodes and it changes as a function of the amount of molecules binding to the surface. A polydimethylsiloxane (PDMS) encapsulant also known as a manifold is used to enable the flow of the reagents into the nanowells onto the sensing sites. The PDMS manifold is fabricated out of biocompatible polydimethylsiloxane. Binding of biomolecules within the nanowells perturbs the charge associated with the electrical double layer formed at the solid/liquid interface. A low voltage alternating current signal (10 mV, 100 MHz to 1 MHz) is applied through the electrodes to the sensor and the impedance changes due to protein binding is measured across the working and counter electrodes. Impedance changes occurring within the entire array of the nanowells is measured thus reducing signal variability during protein detection at low doses (< 1 ng/mL).

B. Principles of Impedance Spectroscopy

The impedance Z of the sensor is generally determined by applying a voltage perturbation with small amplitude and detecting the current response. From this definition, the impedance Z is the quotient of the voltage–time function $V(t)$ and the resulting current–time function $I(t)$:

$$Z = \frac{V(t)}{I(t)} = \frac{V_0 \sin(2\pi ft)}{I_0 \sin(2\pi ft + \varphi)} = \frac{1}{Y} \quad (1)$$

In “(1)”, V_0 and I_0 are the maximum voltage and current signals, f is the frequency, t the time, φ the phase shift between the voltage–time and current–time functions, and Y is the complex conductance or admittance. The impedance measured due to the perturbation of the electrical double layer, is a complex value, since the current can differ not only in terms of the amplitude but it can also show a phase shift φ compared to the voltage–time function. Thus, the value can be described either by the modulus $|Z|$ and the phase shift φ or alternatively by the real part Z_R and the imaginary part Z_I of the impedance. Therefore the results of an impedance measurement can be illustrated in two different ways: using a Bode plot which plots $\log|Z|$ and φ as a function of $\log f$, or using a Nyquist plot which plots Z_R and Z_I .

The name impedance “spectroscopy” is derived from the fact that the impedance is determined at different frequencies rather than just one. Thus, an impedance spectrum is obtained that allows the characterization of the electrical double layer interface including the charge exchange and ion diffusion processes that occur at this interface. To achieve this, the impedance spectrum is often analyzed using an equivalent circuit as shown in Fig. 1(B). This circuit, which commonly consists of resistances and capacitances, represents the different physicochemical properties of the system under investigation [8]. Alternatively, the system can be described based on transfer functions derived from the basic laws of the processes involved, such as electrokinetics, diffusion, partition, etc. In the case of detection of protein biomolecules, the change of one impedance element—a resistance or a capacitance—as a

function of the number of protein (antigen) analytes in the solution is evaluated. It is also possible to correlate the overall impedance to a change in protein concentration. This simplifies the measurements, since it is often sufficient to determine the impedance at just one selected frequency or within a limited frequency window (where the relative changes are largest) in such cases. Hence the Nyquist plot, as shown in Fig. 1(C), enables a good understanding of the protein – antibody interactions and the identification of the specific binding event between the antibody and the antigen. In the current sensing methodology direct interactions between the protein and its receptor is studied without the use of a charge transfer mediator such as redox probe. Typically redox probes are required for achieving sensitivity below the ng/mL regime. The use of confined spaces has enabled the enhancement of the sensitivity without the use of redox probes. Hence the charge perturbation measured at the electrical double layer within the nano sensor is non-faradaic in nature.

C. Experimental Protocol

The first step in designing the sensor is the immobilization of the antibodies/ receptors. These enable the eventual immobilization of the proteins within the nanowells. Stock solution of anti-pro-NT BNP (US Biological, Anti-Brain Natriuretic Peptide, Pro, NT) was diluted to prepare aliquots of anti-BNP ranging from 1 ng/mL to 1 μ g/mL. After integrating the nanomembrane and PDMS manifold onto the chip, 150 μ L of 10 mM Dithiobis succinimidyl propionate (DSP) crosslinker was injected into the manifold and incubated for 30 minutes at room temperature. The sensor surface was subsequently washed three times with 0.15 M PBS and baseline PBS measurements were taken. All the impedance measurements for different concentrations of anti-BNP were normalized to this baseline measurement. Followed by the PBS baseline measurement step, 150 μ L of 10 ng/mL anti-BNP was injected on the sensor surface and measurements were taken after 15 minutes. After each measurement, sensor surface was washed three times with 0.15 M PBS and the process were repeated with next higher concentration of anti-BNP until the saturation dose for anti-BNP (negligible change in impedance with increasing anti-BNP dose) was found[5].

For the protein detection, the protein was aliquoted in isotonic buffer solution, 0.15 M phosphate buffer saline (PBS). Aliquots of Pro-NT BNP ranging from 1 fg/mL to 1 μ g/mL were prepared in a logarithmic scale. These concentrations were selected because they represent clinically relevant concentrations of BNP in physiological conditions.

The chip was initially prepared and DSP cross linker was immobilized in the same manner as detailed above. The sensor surface was subsequently washed with 0.15 mM PBS to remove the unbound DSP. Following the cross linker deposition, 150 μ L of 750 ng/mL anti-BNP was incubated onto the sensor surface for 30 minutes to immobilize the receptors. After immobilizing anti-BNP on the sensing surface, PBS wash was performed three times followed by

incubation of super block, (Thermo Scientific, SuperBlock® blocking buffer) on the sensor surface for 30 minutes at room temperature to minimize non-specific binding; followed by PBS wash performed three times. Zero dose corresponding to 0.15 M PBS was injected into the manifold and the measured impedance was considered as the baseline measurement. All the impedance measurements for different dose concentrations of BNP were normalized to this baseline measurement. Starting from the lowest dose within the range, 150 μ L of BNP spiked buffer was injected into the manifold, incubated for 15 minutes and impedance measurement was taken. The change in impedance from baseline measurement was calculated and converted into percentage change of impedance from baseline readings. After measurement of each dose concentration, the sensor surface was washed three times with 0.15 M PBS and the next higher concentration of doses were injected into the manifold. This process was repeated for the entire concentration range. To demonstrate ability of sensor to detect specific proteins in a biologically realistic environment, the dose response study was also carried out using Human Serum (HS) as the medium of behavior for the proteins.

III. RESULTS AND DISCUSSION

The sensor was designed to perform as an electrical immunoassay. The DSP linker molecules were utilized to immobilize the antibodies. The protein molecules were then introduced and the association between the antibodies and antigens were quantitatively characterized using impedance spectroscopy. Two sets of result have been demonstrated in this section. The first set shows the impedance analysis to determine the dose of the BNP antibody that saturates the sensor surface. The second set of results show the sensor calibration also known as the dose study to determine the sensor response to detecting BNP when challenged with varying concentrations of the protein.

A. Antibody Saturation Study

The sensor surface was pre treated with a covalent linker-DSP which enabled the immobilization of the antibody onto the sensor surface primarily within the nanowells. The sensor was challenged with increasing doses of the antibody (Anti-BNP) over the concentration range from 10 ng/mL to 1 μ g/mL. The sensor impedance response was measured over a frequency range from 100 mHz to 1MHz. When the antibodies were immobilized at the base of the nanowells, an increase in the double layer capacitance at the solid/liquid interface at the base of the nanowell was observed. The increase in the double layer capacitance translated to a decrease in the measured impedance. A dose dependent decrease in the impedance was observed with increasing doses of the antibody, eventually resulting in a steady state impedance measurement that correlated to the antibody saturation concentration. Changes to the double layer capacitance are most significant at the low frequency regime (<1 kHz). Hence the impedance changes due to antibody association with the sensor surface were calculated as a

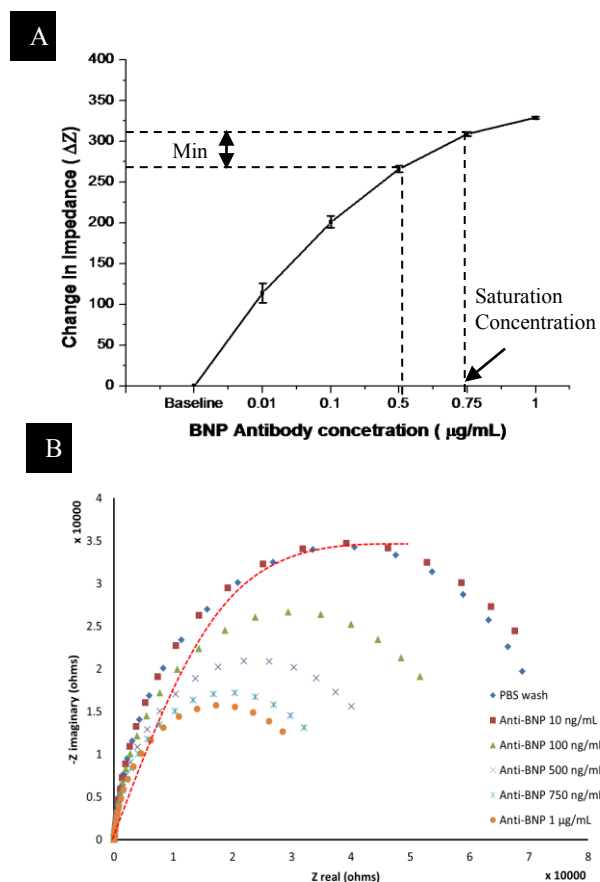

Fig 2: (A) Anti-pro-n terminal brain natriuretic protein (antibody) saturation studies. Changes in impedance with respect to PBS wash as baseline is calculated. Saturation process is started with low concentrations of antibody followed by higher concentrations. ΔZ difference decreases significantly at 750 ng/mL antibody concentration. (B) Nyquist plots for varying antibody concentrations. The frequency scan range was 100 mHz to 1 MHz. The dotted trend line is overlaid as a guide for the eye only.

percentage change in the impedance when compared to the baseline impedance and represented for the frequency $f = 100$ Hz. The baseline impedance corresponded to the impedance measurements due to the interaction of the phosphate buffered saline buffer with the covalent linker molecules prior to the introduction of the antibody molecules. Fig. 2(A) shows the antibody saturation study indicating that at concentrations greater than 750 ng/mL, the sensor surface gets saturated with the antibody molecules. Fig. 2(B) is the Nyquist plot showing the saturating trend as observed with the higher doses of the antibody. Data shown in the paper were obtained from 10 separate measurements. It is critical to saturate the sensor surface prior to challenging the sensor with varying doses of the protein, as an unsaturated sensor surface will result in non-specific binding of the protein to the sensor surface. Non-specific binding would result in signal artifacts.

B. Protein Detection Study

The sensor was challenged with varying doses of protein over the concentration range from 1 fg/mL to 100 ng/mL. Prior to protein injection the anti body saturated sensor surface was treated with super block. Impedance measurements were obtained from the sensor after

superblock treatment. These measurements were considered as the baseline impedance to quantify the sensor response to varying doses of the protein. The PBS wash after each detection cycle is reflective of the binding in the chip before the dose of protein is applied. While this can be used as a reference to understand the specific to non-specific hybridization occurring, it cannot relate to overall hybridization occurring in the chip. This is the reason the PBS wash after SB was used as a baseline because this value of impedance reflects a sensor assay with no hybridization. Starting with the lowest dose, the sensor was challenged with increasing doses of the protein. The impedance changes were evaluated over the frequency range from 100 mHz to 1 MHz. As the changes to the double layer capacitance is maximized at the low frequency regime, impedance changes due to varying doses of the protein were plotted at frequency $f = 100$ Hz. A stepwise increase to the percentage change in impedance was observed. The sensor had a wide linear dynamic range from the fg/mL to the ng/mL with a R^2 value of 0.9929. The coefficient of variance (CV) of the sensor was statistically insignificant. The sensor response for a fixed frequency is shown in Fig. 3(A). The equivalent circuit associated with the sensor is a RC circuit. There is no contribution from R_{ct} , the charge transfer resistance due to the absence of faradaic charge transfer between the biomolecule complex and the substrate. As the redox-active compound is omitted or a blocking layer is applied (super block) to the electrode, capacitive impedance behavior will be observed (since R_{ct} will become extremely large). Thus, a binding event at the sensor can be detected by following the change in capacitance.

As a contrast study, 4 test samples were chosen around the nanogram and picogram regime. The concentrations for these samples were estimated by using the antigen dose curve as a reference. A comparison between the ELISA estimated and sensor assay estimated concentration is shown in Fig.3 (B). The exhibited standard deviation is less than 15%. These test sample studies validate the ability of the laboratory prototype sensor assay to detect BNP protein biomarker in patient samples at clinically relevant concentrations

IV. CONCLUSIONS

In this sensor configuration enhancement in the detection sensitivity is achieved without the use of redox probes. Low dose detection has been achieved by leveraging the size matched confinement architecture of the sensor design. The fixed frequency and Nyquist plots have been used to demonstrate the sensor performance. The limit of detection for the sensor has been observed to be around the 10 fg/mL range. The ELISA estimated and sensor estimated values for the concentrations are shown in Fig 3(B). The variability in estimation is less than 15% and is still under the general limits for method comparison and bias estimation[9].

REFERENCES

[1] F. Lisdat and D. Schäfer, "The use of electrochemical impedance spectroscopy for biosensing," *Analytical and Bioanalytical Chemistry*, vol. 391, pp. 1555-1567, 2008.

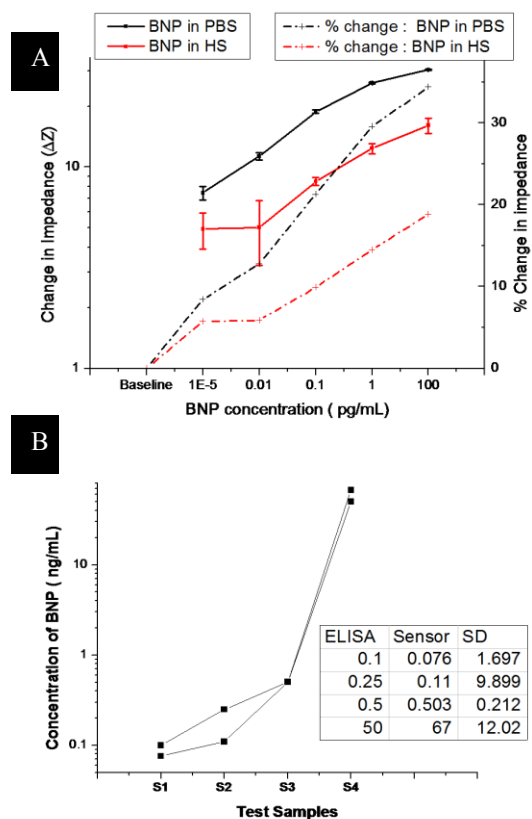

Fig. 3: (A) BNP (antigen) dose response in PBS and HS, indicating the high detection sensitivity into the femtogram regime caused from the presence of the nanoporous alumina membrane. (B). Test sample estimation and comparison between ELISA and constructed sensor assay. The test samples were picked in the ng/ml BNP concentration regime

[2] J. S. Daniels and N. Pourmand, "Label-Free Impedance Biosensors: Opportunities and Challenges," *Electroanalysis*, vol. 19, pp. 1239-1257, May 16 2007.

[3] V. Kunduru, M. Bothara, J. Grosch, S. Sengupta, P. K. Patra, and S. Prasad, "Nanostructured surfaces for enhanced protein detection toward clinical diagnostics," *Nanomedicine: Nanotechnology, Biology and Medicine*, vol. 6, pp. 642-650, 2010.

[4] P. Bettencourt, "NT-proBNP and BNP: biomarkers for heart failure management," *European Journal of Heart Failure*, vol. 6, pp. 359-363, March 15, 2004 2004.

[5] M. Bothara, V. Venkatraman, R. K. Reddy, T. Barrett, J. Carruthers, and S. Prasad, "Nanomonitors: electrical immunoassays for protein biomarker profiling," *Nanomedicine*, vol. 3, pp. 423-436, 2008/08/01 2008.

[6] R. K. Reddy, M. G. Bothara, T. W. Barrett, J. Carruthers, and S. Prasad, "Nanomonitors: Protein Biosensors for Rapid Analyte Analysis," *Sensors Journal, IEEE*, vol. 8, pp. 720-723, 2008.

[7] V. L. Venkatraman, R. K. Reddy, F. Zhang, D. Evans, B. Ulrich, and S. Prasad, "Iridium oxide nanomonitors: Clinical diagnostic devices for health monitoring systems," *Biosensors and Bioelectronics*, vol. 24, pp. 3078-3083, 2009.

[8] N. Fouquet, C. Doulet, C. Nouillant, G. Dauphin-Tanguy, and B. Ould-Bouamama, "Model based PEM fuel cell state-of-health monitoring via ac impedance measurements," *Journal of Power Sources*, vol. 159, pp. 905-913, 2006.

[9] NCCLS, "Method Comparison and Bias Estimation Using Patient Samples; Approved Guideline. NCCLS document EP9-A2 (ISBN 1-56238-472-4)", Second ed, 2002.