

PROTOTYPE FLIGHT MANAGEMENT CAPABILITIES TO EXPLORE TEMPORAL RNP CONCEPTS

Mark G. Ballin, David H. Williams, B. Danette Allen, and Michael T. Palmer

NASA Langley Research Center, Hampton, VA

Abstract

Next Generation Air Transportation System (NextGen) concepts of operation may require aircraft to fly planned trajectories in four dimensions – three spatial dimensions and time. A prototype 4D flight management capability is being developed by NASA to facilitate the development of these concepts. New trajectory generation functions extend today's flight management system (FMS) capabilities that meet a single Required Time of Arrival (RTA) to trajectory solutions that comply with multiple RTA constraints. When a solution is not possible, a constraint management capability relaxes constraints to achieve a trajectory solution that meets the most important constraints as specified by candidate NextGen concepts. New flight guidance functions provide continuous guidance to the aircraft's flight control system to enable it to fly specified 4D trajectories. Guidance options developed for research investigations include a moving time window with varying tolerances that are a function of proximity to imposed constraints, and guidance that recalculates the aircraft's planned trajectory as a function of the estimation of current compliance. Compliance tolerances are related to required navigation performance (RNP) through the extension of existing RNP concepts for lateral containment. A conceptual temporal RNP implementation and prototype display symbology are proposed.

Introduction

Development of the Next Generation Air Transportation System (NextGen) is being undertaken to significantly increase the capacity, safety, efficiency, and security of air transportation in the United States [1]. NextGen is a product of the multi-agency Joint Planning and Development Office (JPDO), and is intended to be transformational, providing revolutionary changes to today's operations to achieve its goals. Two critical areas of transformation are: (1) the

establishment of trajectory-based operations (TBO), requiring planning of, compliance with, and exchange of four-dimensional (4D) flight trajectories; and (2) performance-based operations and services (PBO), in which an aircraft's ability to meet specific performance standards is used to increase the capacity and efficiency of the National Airspace System. The introduction of the time dimension to traditional 3D trajectory generation and guidance may require aircraft to have greater flight path management capabilities than they have today. Future airspace management may require 4D trajectories defined by multiple constraints associated with multiple objectives. Compliance with 4D trajectory clearances may include Required Time of Arrival (RTA) at specified waypoints and/or continuous time containment to a planned trajectory.

This paper describes some of the new airborne capabilities that may be required, and how these capabilities will facilitate proposed NextGen concepts of operation. The paper then describes the development of prototype trajectory generation, flight guidance, and display capabilities to enable critical system research and design needed for NextGen. These capabilities are integrated into a NASA research software flight management system, which is integrated with an air transport aircraft simulation to demonstrate the new capabilities.

Background

4D Concepts of Operation

TBO is based on the premise that increased predictability of flight operations is possible by using precise trajectories and sharing plans for these trajectories with the air navigation service provider (ANSP) and other airspace users. Such increased predictability in turn results in increased capacity, efficiency, and ANSP productivity while maintaining safety [1]. TBO is a shift from today's

tactical management of aircraft through clearances by controllers responsible for regions of airspace, to a more strategic approach of managing individual aircraft trajectories over longer time horizons. TBO relies on future aircraft systems to generate and execute a 4D trajectory, defined as the centerline of an aircraft path in space and time plus a position uncertainty.

Operators who equip their aircraft to conduct TBO will receive services from the ANSP that allow them to achieve operating benefits. Many unequipped aircraft may also benefit if Class B (terminal) airspace can be reduced to active arrival and departure corridors, thereby opening access to the remaining airspace to other operators. TBO also has the potential to facilitate precise control of aircraft separation and spacing in congested environments. Combined with improved weather information, it is expected to allow access to more airspace more of the time, thereby facilitating increased capacity and better utilization of limited airspace and airport resources. TBO will also potentially improve aircraft abilities to fly precise noise-sensitive and reduced-emission departure and arrival paths.

PBO will provide the basis for defining procedures and airspace access in NextGen. Communication, Navigation, and Surveillance (CNS) performance will be the basis for operational approval rather than specific equipage, as in today's system. PBO opens opportunities for limited airspace resources to be managed according to real-time demand and available airborne capabilities. The ANSP will provide performance-based services that give operational advantages to aircraft with higher CNS performance.

All of the 4D trajectory-related concepts and procedures identified by JPDO require Required Navigation Performance (RNP) area navigation (RNAV) capability. RNP is defined as a statement of the navigation performance accuracy necessary for operation with a defined airspace [2]. Additionally, RNP RNAV is defined as an extension of RNP that also includes the containment requirements and area navigation functional and performance standards defined in RTCA DO-236B [2].

New 4D trajectory-related concepts also require the use of Actual Navigation performance

(ANP), which is defined as the navigation computed accuracy with associated integrity for the current FMS position [3]. In other words, ANP is a measure of the quality of the FMS navigational position estimate.

Concepts and procedures defined by JPDO [1] include:

- **Trajectory-based separation management:** Automation and shared trajectory information are used to manage separation among aircraft, airspace, hazards such as weather, and terrain. For aircraft not delegated separation, ANSP automation manages short-term conflict-driven updates to the 4D trajectory. Intent-based conflict detection and resolution is assumed to be necessary. Therefore, a common awareness of the 4D trajectory is required, which requires exchange of the trajectory between the aircraft and the ANSP.
- **Controlled time of arrival:** One or more waypoints of a 4D path may be constrained by the ANSP to require the aircraft to arrive at a specific time within a prescribed performance tolerance. Referred to as a controlled time of arrival (CTA), these constraints are equivalent to the aircraft-centered concept of RTA. Multiple CTA constraints may be specified for flow control purposes.
- **Flow corridors:** Large numbers of separation-capable aircraft may be bundled into corridors during times of high demand. Aircraft self-separate within the corridors while the ANSP maintains separation between the corridor and other aircraft. The concept requires 4D trajectories, CTA, and RNP capabilities for participating aircraft. An analysis of one detailed version of the concept is provided in [4].
- **Airborne merging and spacing:** Aircraft capable of 4D trajectory management are instructed to achieve, and in some operational concepts, maintain spacing from an ANSP designated lead aircraft. This procedure requires a concept of

relative 4D trajectory management rather than Earth-referenced trajectory management.

- *Trajectory-based surface operations:* Procedures proposed for surface operations include the scheduling of active runway crossings and self-separation.

In addition, JPDO research issue R-30 states that some high-density operations may require airborne self-separation capability. Self-separating aircraft must also have 4D trajectories with sufficient flexibility to allow for separation maneuvers [1]. Therefore, other concepts such as 4D-ASAS [5] may be an element of NextGen, and will require airborne 4D trajectory management.

A fundamental issue common to all concepts is the required level of trajectory specification. While some concepts rely on negotiation and/or control of the entire trajectory, other concepts consider the object of agreement and negotiation to be limited to the ANSP-managed constraints themselves, and permit the flight crew to modify the trajectory to meet those constraints [6]. No single airborne guidance approach can support the full spectrum of concepts. Substantial research is also needed to determine aircraft performance requirements associated with each proposed concept, and under what circumstances flight crews can be permitted to fly tactically. Because all JPDO-proposed concepts require trajectory exchange with the ANSP and/or other aircraft, this fundamental issue must be substantially resolved to define a trajectory exchange communication protocol that is common to the ANSP and all participating aircraft.

FMS Time Management

With renewed emphasis on 4D trajectories and time management in the JPDO NextGen concepts, it is useful to review the history and current status of 4D flight management. In particular, we shall discuss the development of 4D trajectory management capabilities at NASA Langley Research Center.

A primary capability of existing Flight Management Systems is the ability to compute 4D flight trajectories for a given flight plan. Most systems use aircraft performance data and forecast

winds to generate trajectories that are flyable by the airplane. Since FMS trajectory predictions normally contain time as an element of the trajectory, many attempts have been made to also control the flight time of the aircraft to achieve specified time goals [7-11].

At NASA Langley, research on 4D flight management began in the early 1970s with the development of the Terminal Configured Vehicle (TCV) [12]. This highly modified Boeing 737 aircraft incorporated a unique research cockpit featuring avionics originally developed by Boeing for the Supersonic Transport program during the 1960s. The digital FMS in the TCV included a novel control mode that enabled tracking of a 4D trajectory. This FMS first generated a 4D trajectory based on pilot-specified altitudes and ground speeds at a series of waypoints, and then issued pitch, roll, and speed commands to enable the 4D control system to precisely track the lateral, vertical and ground speed profiles.

The original TCV FMS, while effective, did not consider aircraft performance in the generation of the 4D trajectory. During the 1980s, performance-based vertical trajectory generation was added to the system [13]. Later enhancements included industry-standard ARINC data interfaces, and the system eventually became the cornerstone of research involving 4D Air Traffic Management conducted at Langley. Fundamentally, however, the core trajectory generation and tracking guidance has remained the same.

During this same time period, other time management concepts have resulted in new requirements for the FMS, as previously detailed. In addition, government and industry standards on RNP have expanded and formalized how airborne FMS trajectories are defined and flown. These new developments have driven the need for an updated 4D flight management research capability.

Prototype Capabilities

A prototype software flight management system with expanded 4D flight guidance capabilities is being developed by NASA to meet this need. Referred to as 4D-FMS, the system incorporates a flexible 4D trajectory definition with

4D guidance for exploring and evaluating different methods of time control.

The 4D Trajectory

The key to any 4D guidance system is the definition of the 4D trajectory. The NASA prototype incorporates industry standard flight plans consisting of ARINC-specified lateral legs that are strung together from an origin (either an airport or current aircraft location) to a destination (airport, runway or arbitrary end point). The significant components of the 4D trajectory are listed below and illustrated in Figure 1.

- Leg – an ARINC 424 industry-standard leg.
- Route – the entire flight plan made up of a sequence of legs.

- Route Segment – the portion of the route made up of the leg(s) between waypoints with crossing constraints.
- Lateral Segment – an individual piece of the lateral trajectory.
- Vertical Segment – an individual piece of the vertical trajectory.
- Flight Phase – a collection of vertical segments that constitute a unique vertical trajectory component, such as cruise or descent.

Figure 1 illustrates a flight plan consisting of 13 lateral legs, each terminating at a waypoint.

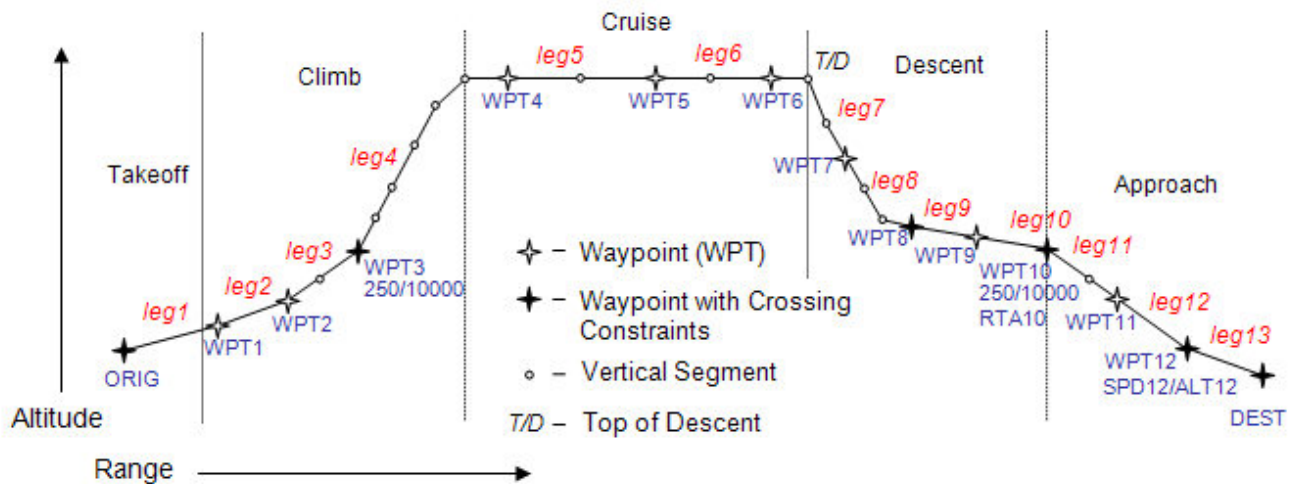

Figure 1. The 4D Trajectory

There are 5 route segments that connect the legs between hard altitude, speed, and/or time crossing constraints. Within each route segment, there are multiple lateral and vertical segments that define the actual flight trajectory. These segments represent the individual pieces of the trajectory as output by the trajectory generator and used by the guidance system for steering the aircraft along the flight plan.

4D Guidance and Control

Guidance and control within the 4D-FMS involves trajectory generation, horizontal guidance

and vertical guidance, as illustrated in Figure 2. The trajectory generator creates the lateral and vertical path definitions from the aircraft flight plan. The path definitions are a function of cost index (CI), which is the ratio of the time-related cost of an airplane operation and the cost of fuel. These path definitions are then used by the horizontal and vertical guidance routines to steer the aircraft. There is a feedback loop from vertical guidance to trajectory generation that controls trajectory prediction based on vertical guidance errors and status. This feedback is significant since some time guidance concepts rely on trajectory prediction to achieve the time objectives.

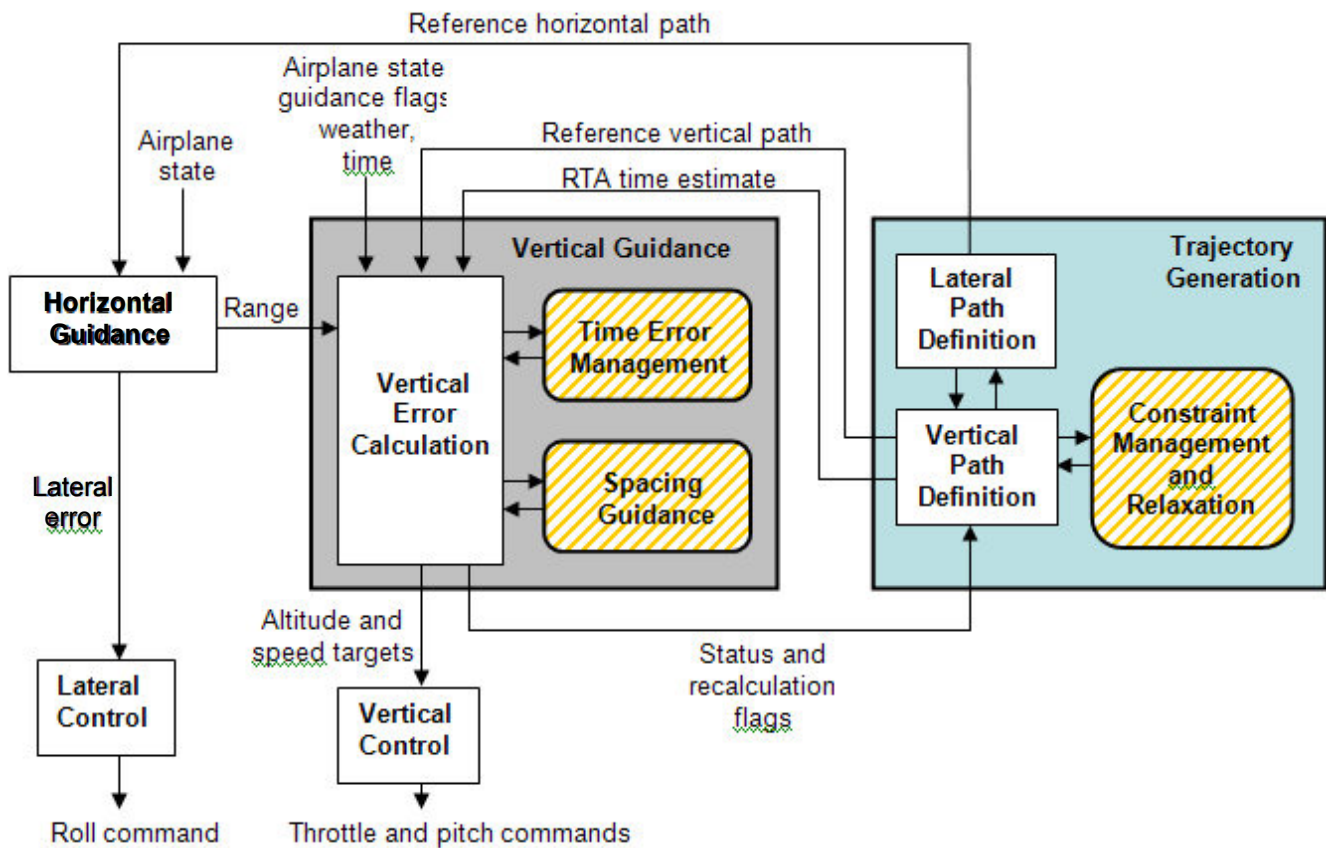

Figure 2. Diagram of Prototype 4D Guidance and Control System

The specific areas of expanded research capability in the 4D-FMS are highlighted in yellow and hatched in Figure 2. These areas include Time Error Management, Spacing Guidance, and Constraint Management and Relaxation.

Management of Multiple Constraints

For concepts that require compliance with RTAs at more than one waypoint, a capability was developed to enable the 4D-FMS to comply with multiple RTAs. The end conditions of an RTA waypoint are used as the initial conditions for the route segments to the next RTA waypoint. Separate CI limits and tolerance values are computed and maintained for each RTA route segment.

As shown in Figure 2, a new Constraint Management and Relaxation (CMR) function was developed as an outer loop of the vertical path definition function. If multiple specified RTA

constraints are not achievable due to aircraft performance limitations, CMR provides the capability to relax RTA constraints within specified tolerances. Any number of RTAs may be specified. Figure 3 defines terms and illustrates RTA relaxation for an example having three RTAs. It shows estimated time of arrival (ETA) windows, represented by grey boxes, with respect to the time of flight. The left edge of the window is the earliest time the aircraft can arrive at the RTA waypoint by flying as fast as possible, and the right edge is the latest time, achieved by flying as slow as possible. RTA times are represented by triangles. Original RTAs and ETA windows are shown in the upper part of Figure 3, and they are shown after constraint relaxation in the lower part.

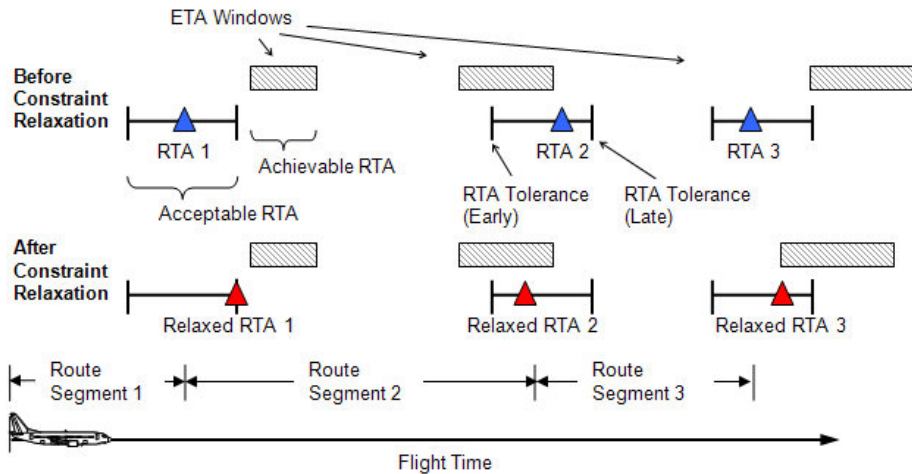

Figure 3. RTA Relaxation

Constraints are relaxed based on estimates of the earliest and latest achievable times for a given RTA. The ETA window is generated by setting the CI equal to its maximum and minimum values and generating the corresponding trajectory. At least two calls to the trajectory generator are required: before the CMR iteration to define the ETA windows and after exiting the iteration to verify that the ETA times have not changed relative to their upstream RTAs, which may have shifted in time. ETA relative times do not change as a result of the second call if the trajectory generator uses no time-varying information in the generation of the trajectory, such as time-varying wind forecasts.

CMR uses a set of tolerances to define an acceptable range of RTA relaxation. Flight times corresponding to early and late RTA tolerances are shown in Figure 3 by the vertical bars for each RTA. In the current 4D-FMS implementation, these tolerances correspond to the RTA crossing limits, to be described later. Some operational concepts may instead specify that these values be uplinked from the ANSP. If a relaxed RTA is within this tolerance window, it is defined as acceptable. If the relaxed RTA does not fall within the ETA window even after a full relaxation to a tolerance limit, as shown for RTA 1, the RTA is not achievable and an “Unable RTA” message is sent to the multifunction control display unit (MCDU) for display to the flight crew.

Each ETA window is based on the time required for the aircraft to travel the constant

distance from the beginning of the route segment to the RTA waypoint. Therefore, a time shift of a previous RTA may result in a shift of the ETA window in absolute time, even though the time required to travel the distance between waypoints does not change. If the previous RTA is within its ETA window and its relaxed value is also within its ETA window, the shift of the downstream ETA window corresponds directly with the RTA shift, as shown by RTA 3 in Figure 3. If an RTA is not achievable, the aircraft will always fly to the nearest “best-effort” value. Therefore, if either the original or the relaxed upstream RTA is not within its ETA window, the downstream shift corresponds only to the portion of the upstream RTA change that is within the window. The ETA window of RTA 2 illustrates this. Because the RTA 1 tolerance region does not overlap with its ETA window, the FMS will fly the route segment at the fastest speed possible, which corresponds to the left edge of the ETA window. There is no change in arrival time at the waypoint corresponding to RTA 1, so there is no time shift in the downstream ETA window.

Methods of Time Control

The 4D-FMS has three fundamental methods of time control guidance available for studying time-based operational concepts. The first is RTA predictive guidance, which is designed to achieve RTAs at discrete waypoints using trajectory prediction techniques. The second is continuous time control guidance that steers the aircraft along a pre-computed trajectory while maintaining and/or

achieving time accuracy along the way. The third is trajectory-based spacing relative to a leading aircraft. These methods are described in the following sections.

RTA Predictive Guidance – RTA time control relies on trajectory prediction to generate a flight trajectory that achieves the desired arrival time. The trajectory generator will iterate on possible trajectories until the ETA at the RTA waypoint is within a pre-specified tolerance of the RTA. There are a number of methods for accomplishing this iteration. The 4D-FMS uses the CI as the independent variable for this iteration because past research has shown this method results in a trajectory that is fuel optimal for the prescribed flight time [14-15]. Once a predicted trajectory that achieves the RTA has been generated, the airplane will fly normal FMS guidance (roll, pitch and speed) relative to it. Periodically, the trajectory generator will update the estimated arrival time, as well as the maximum and minimum arrival times, from the current aircraft location along the reference trajectory to the RTA waypoint. This update is done approximately every 15 seconds in the 4D-FMS. If the estimated time of arrival is earlier or later than the RTA by more than a set time error tolerance, the 4D-FMS will trigger a new trajectory iteration to meet the RTA. The FMS will then provide guidance relative to this new trajectory. This process continues until the aircraft arrives at the RTA waypoint or the RTA is deleted from the flight plan.

The time error tolerance between the estimated and required arrival time is computed based on the arrival time limits at the RTA waypoint and the flight time remaining to the waypoint. The tolerance may be greater the further the airplane is from the RTA waypoint. This is done to inhibit unnecessary updates and reduce the computational load on the FMS trajectory generator. Details of the time error tolerance are discussed in the section on Temporal RNP.

Continuous Time Control Guidance – Continuous time control provides the capability to manage the flight time of the aircraft along a pre-computed 4D reference trajectory. Time errors are based on the current location of the aircraft relative to this computed trajectory rather than on the estimated arrival time at some future RTA

waypoint. This guidance method may be necessary for operational concepts that require negotiated “contract” trajectories. If the trajectory has been computed to achieve an RTA at a specified waypoint, the aircraft achieves this RTA by adjusting speed throughout the flight to track the time profile of the reference trajectory.

The 4D-FMS uses CI iteration to generate the reference trajectory. The continuous time guidance function then “flies” a reference time box along this trajectory to provide a dynamic reference for computing the speed guidance signals necessary to track the time profile. This technique was originally developed for the NASA Transport System Research Vehicle as described in [13]. The method has proven effective in achieving precise time control, including meeting individual RTAs.

Within the aircraft performance envelope, the reference trajectory does not need to be recomputed to achieve compliance. However, wind forecast errors during the reference trajectory computation may cause unnecessary fuel consumption. The errors may also cause the aircraft to encounter its performance limits, thereby preventing trajectory compliance. Periodic updates to the reference trajectory improves the fuel efficiency of this technique by incorporating updated wind information and reducing the need for throttle and/or speed brake to track the time. Because the periodic updates modify the reference trajectory, they are not appropriate for concepts requiring a trajectory contract unless the contract permits periodic incremental trajectory changes.

The 4D-FMS incorporates the same time tolerance strategy for the continuous time mode as it does for the RTA predictive mode. This tolerance is applied to the instantaneous time error relative to the reference time trajectory. The target speed of the 4D-FMS is adjusted to keep the airplane within these time tolerances throughout the flight. The 4D-FMS also allows specifying a constant time error that overrides the default and RTA based limits.

Relative Trajectory-Based Spacing – Relative spacing involves establishing spacing intervals relative to another aircraft at a prescribed time interval rather than achieving an absolute time objective. The use of trajectory prediction as an element of spacing guidance enables following a

lead aircraft while flying a different route that merges to some common route segment or runway. It also enables aircraft to execute fuel-efficient descents while following a lead aircraft with different performance characteristics. The NASA Airborne Spacing for Terminal Arrivals (ASTAR) algorithm [16] has been incorporated within the 4D-FMS to provide relative spacing capability.

Temporal RNP and ANP

The 4D trajectory generation and time control guidance concepts described above may require the definition and use of time-based, or temporal, RNP. The concept of temporal RNP introduced here is a straightforward extension of RNP from the cross-track, or lateral, sense to the along-track, or longitudinal, sense. As shown in Figure 4, longitudinal RNP starts with a specification of the maximum amount of allowable along-track deviation, expressed in time, and then converts this value into distance by multiplying by the aircraft groundspeed. Temporal RNP can be interpreted as the maximum number of seconds that an aircraft is permitted to be either early or late relative to a nominal time profile for that procedure or flight plan leg. The aircraft shown in Figure 4 is clearly outside of the permissible temporal RNP, because the range error exceeds the longitudinal RNP.

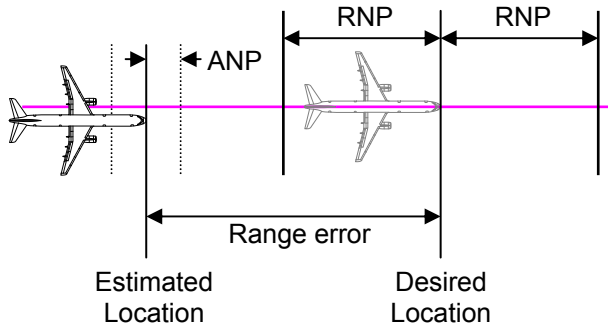

$$\text{Longitudinal RNP} = \text{Temporal RNP} * \text{Ground Speed}$$

$$\text{Temporal ANP} = \text{Longitudinal ANP} / \text{Ground Speed}$$
 For RTA mode:

$$\text{Range error} = (\text{ETA-RTA}) * \text{Ground speed}$$

Figure 4. Relationship between Longitudinal and Temporal RNP

Default temporal RNP values may be established for procedures and flight plan legs in different types of airspace. These values will be concept-dependent. Proposed values for each airspace type, solely for use in the prototype implementation of these temporal RNP/ANP concepts, are presented in Table 1.

Table 1. Proposed Temporal RNP Values

Phase of Flight	Default RNP (sec)
En Route Oceanic	180
En Route Domestic	90
Terminal Area Departures	180
Terminal Area Arrivals	30
Approach	15

The default temporal RNP values can also be adjusted to achieve more restrictive waypoint crossing limits. This technique, referred to as dynamic temporal RNP in this paper, permits a smooth transition from a leg-based RNP to a waypoint crossing RNP. This concept is implemented in 4D-FMS using the time tolerance function shown in Figure 5.

Default Leg Tolerances:
 Cruise: 120 sec
 Arrival: 30 sec
 Approach: 15 sec

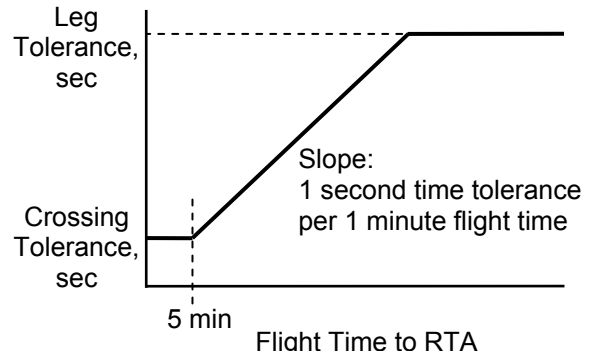

Figure 5. Time Tolerance Calculation

Temporal ANP is similarly introduced here as the estimated position uncertainty in the along-track, or longitudinal, sense. Temporal ANP is readily computed from the current lateral ANP value, because this lateral position uncertainty actually describes the diameter of a circle within which the true position of the aircraft is likely to lie. The longitudinal ANP is therefore equal to the

lateral ANP in nautical miles, and the temporal ANP in seconds is computed by dividing the longitudinal ANP by the current aircraft groundspeed. Figure 4 illustrates the relationships described above between the estimated ownship locations, the longitudinal and temporal RNP, and the longitudinal and temporal ANP.

Implementation

The 4D-FMS has been implemented as a multi-threaded, object-oriented design integrated into the existing NASA RPFMS code base. The design includes one real-time thread for guidance calculations and data exchange, with multiple background threads for trajectory generation and spacing calculations. The existing RPFMS flight planning and system interface code has remained essentially the same with minor modifications added to support the new pilot interface features.

Prototype Interface

The interface to the prototype implementation of these new temporal RNP/ANP concepts is

essentially limited to two main elements: (1) the display of new temporal RNP/ANP symbology on the navigation display (ND), as shown in Figures 6 and 7; and (2) the extension of the current RNP PROGRESS page on the MCDU to include temporal RNP/ANP values. Multiple RTA progress pages are used to allow flight crew modification of RTA times and tolerances. Examples of these displays are shown in Figure 7.

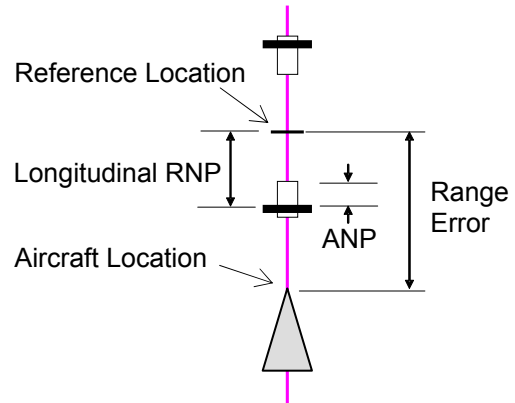

Figure 6. ND Symbology for Temporal RNP/ANP



Figure 7. Prototype Implementation Interface of Temporal RNP/ANP

Examples of Operation

The 4D-FMS was integrated with a NASA transport aircraft simulation and a series of simulations was conducted in the NASA Langley Air Traffic Operations Laboratory to test and illustrate the new time control features of the 4D-FMS. Examples of simulation outputs are provided for RTA relaxation and time guidance.

RTA Constraint Management

An example RTA relaxation is shown in Figure 8. The aircraft has an initial position

approximately 30 minutes prior to the Borger waypoint (BGD) on a flight plan to Atlanta. RTAs are specified at BGD, at Memphis (MEM), which is a few minutes prior to the top of descent, and at the NOFIV RNAV fix, which is the bottom of descent. RTA 3 is approximately one minute earlier than the aircraft can achieve. CMR relaxes RTA 3 to its tolerance limit and shifts ETA window 3 earlier by relaxing RTAs 1 and 2. By relaxing RTA 1, ETA window 2 is also shifted earlier, which allows RTA 2 to be relaxed to its tolerance limit.

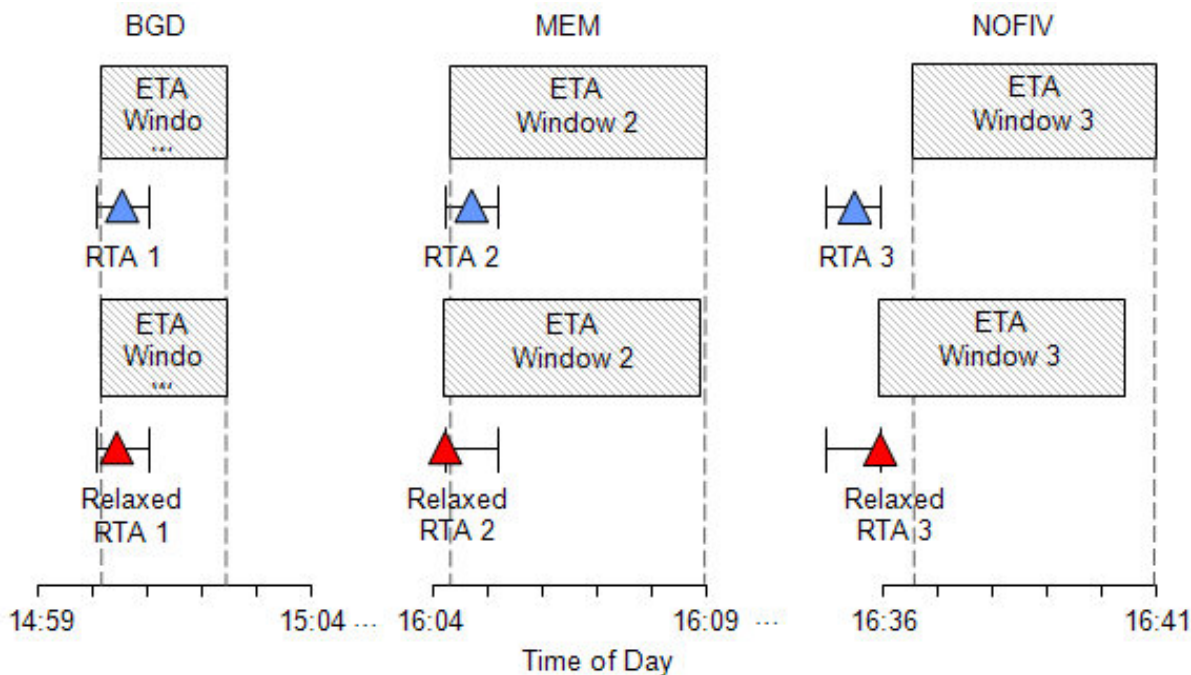

Figure 8. Example of RTA Constraint Relaxation

ETA window time ranges are small for the example. Limited aircraft speed flexibility in cruise limits the ETA range and therefore significantly reduces the net benefit of constraint management. NextGen concepts may need to consider permitting flight replanning to increase the ETA windows. Future integration of the NASA Autonomous Operations Planner (AOP) [17] with 4D-FMS will enable study of the impacts of airborne flight plan changes on the concepts. Lateral path stretches, altitude changes, and movement of the top of descent point may be beneficial for delay absorption, and accurate gridded wind forecasts may enable occasional replanning that reduces delay.

Time Guidance

Figure 9 illustrates the behavior of continuous 4D time guidance and RTA time guidance in the presence of a dynamic temporal RNP. Two RTA waypoints were added to a flight plan into the Atlanta terminal area. The first was at cruise altitude with a time crossing tolerance of 15 seconds (DEVAC in Figure 9). The second was at bottom of descent with a time tolerance of 5 seconds (NOFIV). The temporal RNP is seen to linearly reduce as a function of flight time to each of these RTA crossing limits. The temporal RNP then remains constant at the RTA crossing tolerance for 5 minutes prior to the RTA waypoint crossing. The RTA time error exhibits a series of discrete updates as the trajectory is regenerated when the

RNP boundary is reached or exceeded. The time error temporarily exceeds the RNP boundary occasionally since there may be small delays before the new reference trajectory generation is completed. The continuous 4D guidance exhibits

more gradual changes as the time error is kept within the RNP bounds. The 4D-FMS control law uses both reference profile ground speed as well as time error in order to compute speed commands to contain the time error within the RNP bounds.

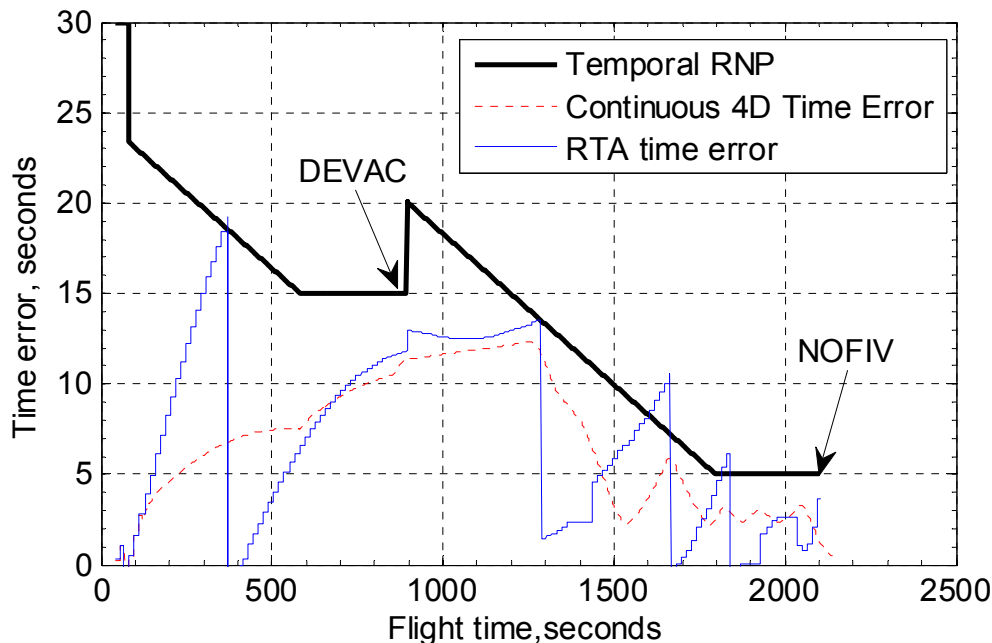

Figure 9. Example of Time Guidance Behavior

Conclusions

A research FMS has been developed that enables operations research critical to the development of NextGen concepts. Trajectory planning and control options have been developed that span the range of 4D control under consideration, from 4D trajectory specification at all times to concepts that rely on trajectory specification only at points of constraint. Integrated with multi-aircraft simulations, full-mission simulators, and research aircraft, it will be critical in determining the extent of trajectory control that is required by centralized service providers to achieve NextGen objectives. It will support the understanding of trade-offs associated with the various levels of control, including fuel consumption and operator flexibility. It will also support research of trajectory exchange between the aircraft and the ANSP and with other aircraft. It will support the development of a common trajectory language for interoperability within and between airborne and ground-based automation, and the

determination of trajectory exchange requirements for considered concepts. In addition to the trajectory guidance options, 4D-FMS configuration options include either a pilot or a data link source of trajectory constraints and tolerances, and the control of relative importance of multiple RTAs.

Many areas of development remain. A forecast wind error probability model is needed to provide pilots with ETA uncertainty estimates and to integrate ETA uncertainty with constraint relaxation. Enhanced trajectory generation and guidance functions for efficient energy management during climbs and descent are being developed. Further constraint relaxation options will be added to support new concepts. One such option is the variation of cruise altitude to meet RTA constraints. RTA importance weighting will be further explored. An option will also be added to close the guidance loop around relaxed RTA values instead of original RTA values, as currently implemented. Flight crew decision support research will also require development of capabilities and options for

display content, message content and annunciation, override and trajectory modification, and path recovery. In the future, 4D-FMS will also be integrated with the AOP, thereby enabling exploration of constraint management integrated with lateral and vertical path replanning.

References

- [1] Joint Planning and Development Office, June 13, 2007, Concept of Operations for the Next Generation Air Transportation System, Version 2.0.
- [2] RTCA, October 28, 2003, RTCA DO-236B, Minimum Aviation System Performance Standards: Required Navigation Performance for Area Navigation.
- [3] Boeing Corporation, January 14, 2003, RNP Capability of FMC Equipped 737, Generation 3, Document No. D6-39067-3 Rev. A.
- [4] Wing, D. J., J. C. Smith, M. G. Ballin, July 2008, Analysis of a Dynamic Multi-Track Airway Concept for Air Traffic Management, NASA TP-2008-215323.
- [5] Wing, D. J., 2005, A Potentially Useful Role for Airborne Separation in 4D-Trajectory ATM Operations, AIAA-2005-7336, 5th AIAA Aviation Technology, Integration and Operations Conference, Arlington, VA.
- [6] Wing, D. J., September 2008, Performance Basis for Airborne Separation, 26th Congress of the International Council of the Aeronautical Sciences (ICAS), Anchorage.
- [7] Lee, H. P., M. F. Leffler, February 1984, Development of the L-1011 four-dimensional flight management system, NASA CR 3700.
- [8] DeJonge, M.K., 1988, Time Controlled Navigation and Guidance for 737 Aircraft, Aerospace and Electronics Conference, NAECON.
- [9] Eurocontrol, 1999, PHARE Advanced Tools Project Final Report, Doc 98-70-18 (Volume 1 of 10), Bruxelles.
- [10] Jackson, M. R. C., V. Sharma, C. M. Haissig, M. Elgersma, Dec. 2005, Airborne Technology for Distributed Air Traffic Management, Decision and Control, 2005 European Control Conference, CDC-ECC '05, 44th IEEE Conference on Decision and Control, pp. 3947-3954.
- [11] Korn, B., A. Kuenz, Oct. 2006, 4D FMS for Increasing Efficiency of TMA Operations, 25th Digital Avionics Systems Conference, IEEE/AIAA.
- [12] Wallace, Lane E., 1994, Airborne Trailblazer: Two Decades with NASA Langley's Boeing 737 Flying Laboratory, NASA SP 4216.
- [13] Williams, David H., Steven M. Green, March 1991, Airborne 4D Flight Management in a Time-Based ATC Environment, NASA TM 4249.
- [14] Sorensen, J. A., M. H. Waters, May 1981, Airborne Method to Minimize Fuel with Fixed Time-of-Arrival Constraints, Journal of Guidance and Control, Vol. 4, pp. 348-349.
- [15] Burrows, J. W., Jan. 1983, Fuel-Optimal Aircraft Trajectories with Fixed Arrival Times, Journal of Guidance and Control, Vol. 6, pp. 14-19.
- [16] Barmore, B., Oct. 2006, Airborne Precision Spacing: A Trajectory-Based Approach to Improve Terminal Area Operations, 25th Digital Avionics Systems Conference, IEEE/AIAA.
- [17] Ballin, M. G., V. Sharma, R. A. Vivona, E. J. Johnson, and E. Ramiscal, August 2002, A Flight Deck Decision Support Tool for Autonomous Airborne Operations, AIAA-2002-4554.

Acknowledgments

The authors gratefully acknowledge the assistance of Joel Klooster, Keith Wichman, and Mike DeJonge of GE Aviation Systems; Thomas Britton, John Barry, Fred Hibbard, Lucas Hempley, and Erick Crouse of Lockheed Martin; and sponsorship of the NASA Airspace Systems and Innovative Partnerships Programs.

*27th Digital Avionics Systems Conference
October 26-30, 2008*