

AVIATION COMMUNICATIONS EMULATION TESTBED

Charles Sheehe, NASA Glenn Research Center, Cleveland, Ohio

Tom Mulkerin, Mulkerin Associates Inc., Springfield, Virginia

Abstract

Aviation related applications that rely upon datalink for information exchange are increasingly being developed and deployed. The increase in the quantity of applications and associated data communications will expose problems and identify issues to resolve. NASA's Glenn Research Center is developing an aviation communications emulation testbed for studying the communications issues that will arise as datalink applications are employed within the National Airspace System (NAS).

The Testbed is evolving and currently provides the hardware and software needed to study the communications impact of Air Traffic Control (ATC) and surveillance applications in a densely populated environment. The communications load associated with up to 160 aircraft transmitting and receiving ATC and surveillance data can be generated in real-time in a sequence similar to what would occur in the NAS. The ATC applications that can be studied are the Aeronautical Telecommunications Network's (ATN) Context Management (CM) and Controller Pilot Data Link Communications (CPDLC). The Surveillance applications are Automatic Dependent Surveillance - Broadcast (ADS-B) and Traffic Information Services - Broadcast (TIS-B).

Introduction

NASA's Glenn Research Center (GRC) has been performing Communications, Navigation and Surveillance (CNS) research under an element of the Airspace Systems Program. GRC's activities have resulted in new tools for studying CNS technologies.

A new project under the NASA Exploratory Technologies for the National Airspace System Program (NEXTNAS) is planned to further enhance GRC's activities for the research and development of CNS technologies. This project is known as Advanced CNS Architectures and System Technologies (ACAST). The project has been established to enable the transfer of network-based digital information. This capability is essential to

facilitate the effective functioning of the new airspace management systems being developed for the long term. Hence, a research and development effort for a future CNS infrastructure, in parallel with the airspace system management research, is needed. ACAST fills this need.

The impact that data link traffic loads will impose on the underlying communications infrastructure within the NAS is not well known. To better understand this impact, GRC is developing (in stages) an emulation and test facility to study data link interactions and the capacity of the NAS infrastructure to support the data communications requirements of various applications. The Virtual Aircraft and Controller (VAC) Testbed provides a means of observing the operation of large-scale aeronautical data link communications using different subnetworks.

Communications Testbed Concept

GRC's capability to study the effects of communications on the NAS has been evolving. A study of the NAS's digital communications requirements for 2015 was conducted in 1998. The project was referred to as Task Order 24. The TO 24 study pointed out that a good communications model of the NAS did not exist and one should be developed.

Modeling the NAS with all its complexities was beyond the scope that NASA wanted to undertake. It was decided to look at a smaller area that could represent a worst-case traffic loading situation. The smaller area that NASA chose was the Los Angeles basin in the year 2020 with the expected aircraft and infrastructure equipages.

As an initial step in developing a communications testbed, GRC undertook an engineering study effort to develop the Global Aviation Communications Test and System Emulation Facility (GACTSEF). NASA decided that GACTSEF should incorporate every communications system that will be fielded in the NAS. Since funding

was limited, it was decided to build the facility envisioned in the GACTSEF study incrementally.

The concept that resulted from the GACTSEF study has been refined into the Virtual Aircraft and Controller (VAC) Testbed shown in Figure 1.

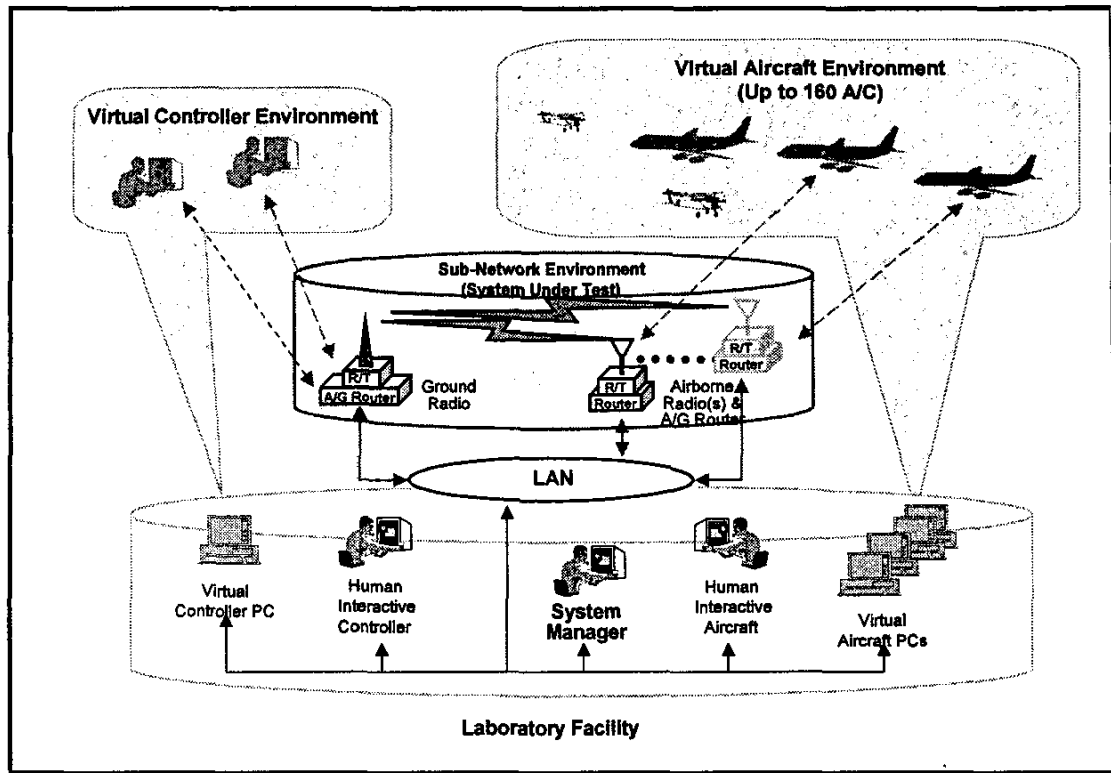

Figure 1. GRC's Communications Emulation Testbed

Evolutionary Development

The GACTSEF implementation started with the first phase of the VAC Testbed. It provided the capability for a single Air Traffic Control (ATC) controller to exchange Controller Pilot Data Link Communications (CPDLC) messages with five aircraft in real time. A "pilot" would enter a CPDLC message on a simulated aircraft display and send it via a communications network to the controller.

The second phase added a scripting capability that permitted large-scale emulation of the communications exchanges. As many as 160 scripted aircraft can exchange CPDLC messages with multiple, virtual controllers.

The third phase added a VHF Digital Link (VDL) Mode 2 subnetwork to the VAC Testbed. VDL Mode 2 is the communications subnetwork that is supporting the FAA's CPDLC Build I operations in the Miami ARTCC.

The fourth phase added a surveillance function by adding Automatic Dependant Surveillance - Broadcast (ADS-B) and Traffic Information Service - Broadcast (TIS-B) capabilities to the Testbed during the first part of 2004.

The future phases involve true emulations of the radio frequency environment. This will allow Doppler shift correction, delay, and angle of arrival and reception variations due to antenna placement and patterns.

ATN Emulation

Aeronautical Telecommunications Network

The Aeronautical Telecommunications Network (ATN) comprises application entities and communication services which allow ground, air-ground and avionics data subnetworks to interoperate by adopting common interface services and protocols based on the International Organization for Standardization (ISO) Open Systems Interconnection (OSI) reference model. The ATN is a worldwide, data communications network for the aviation industry. It integrates a broad array of telecommunications systems and services used around the world. The ATN uses many existing telecommunications links and services, creating an "Aeronautical Global Internet" to distribute information between aircraft and ground stations supporting air traffic control, flight and airport operations, flight information services, maintenance communications, and even passenger services.

Improvements in aviation system capacity and safety will require significant advances in the sharing of data among a host of different data nodes, systems, and networks, including all aspects of the aviation system, both airborne and ground-based. Data sharing requirements over the ATN will expand greatly and continuously into the future.

ATN Application Descriptions

The ATN applications that are emulated in the VAC Testbed are Context Management (CM) and Controller Pilot Data Link Communications (CPDLC).¹ CM provides a logon service allowing initial aircraft introduction into the ATN and a directory of other data link applications on the aircraft. It also includes functionality to forward addresses between Air Traffic Service (ATS) units.

CPDLC is an ATN application that provides a means of ATC data communication between controlling, receiving or downstream ATS units and the aircraft, using air-ground and ground-ground subnetworks. The CPDLC data messages use phraseology that is consistent with the International

Civil Aviation Organization (ICAO) phraseology for current ATC voice communications.

VAC Testbed - ATN Components

The first and second phases of the Testbed's evolution are focused on implementing the ATN applications of CM and CPDLC. The Testbed ATN components are composed of software applications (the Applications) developed by Computer Networks & Software, Inc. that interface with routers using the Connectionless Network Protocol (CLNP), which is the ATN network layer protocol. The routers, in turn, are connected to aircraft and ground-based data link radios.

The Applications provide a virtual aircraft / controller capability that emulates pilot/controller data link exchanges from as many as 160 aircraft using script-driven events. The Applications generate CM and CPDLC messages that are ATN compliant, the protocol standard that has been implemented by the FAA in the CPDLC Build I system. The CPDLC message set includes all the messages in Aeronautical Data Link Service (ADLS) Baseline I, which is the set of messages that was to be implemented in the FAA's CPDLC Build IA program.

The Testbed also includes workstations with aircraft and controller graphical user interfaces at which pseudo pilots and controllers can generate and respond to CM and CPDLC messages. The ATN components of the Testbed's architecture are shown in Figure 2.

The VAC Testbed software provides script-driven (referred to as autonomous) and human-interactive message emulation. End-to-end emulation is provided through script-driven, departure-through-arrival scenarios that support a full range of communications test activities. It is complimented by a human-interactive capability where users can enter messages using controller and aircraft displays.

The System Manager application provides configuration control, scenario and script selection, experiment management, and data reduction and analysis capabilities.

¹ Manual of Technical Provisions for the Aeronautical Telecommunication Network (ATN), ICAO DOC 9705/AN956, 2nd Edition, International Civil Aviation Organization, 1999

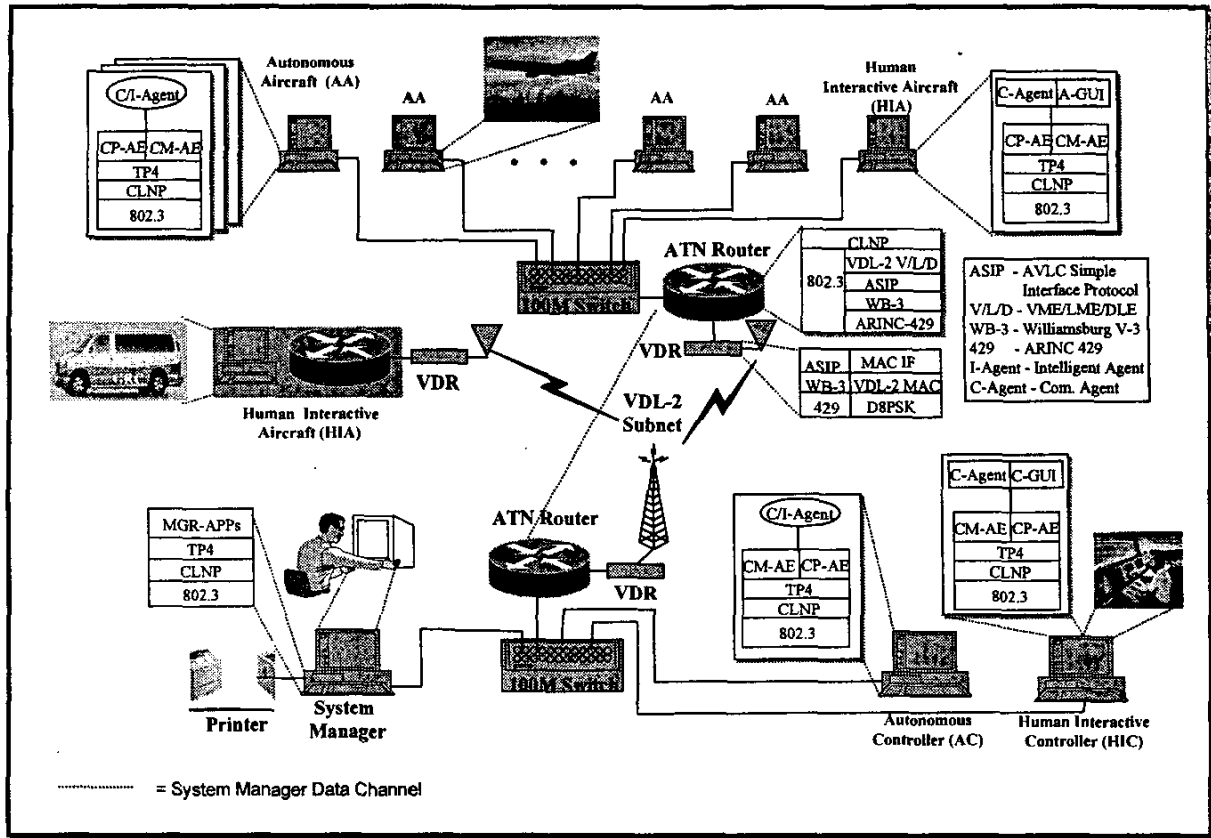

Figure 2. CM and CPDLC Communications Architecture

Autonomous Aircraft

From 1 to 160 Autonomous Aircraft (AA) can be included in an experiment. The autonomous aircraft reside on workstations (personal computers), with multiple aircraft assigned to each workstation. The workstation receives its configuration from the System Manager and launches each aircraft at the appropriate time. The application builds and transmits the CM and CPDLC messages at the scripted time. The AA also responds to messages received from the controller. Transmitted and received CM and CPDLC messages are encoded/decoded, time-stamped, and stored for later reduction.

Autonomous Controller

The autonomous controller provides the System's Air Traffic Management portion of the test and experiment capability. It initiates and

responds to scripted air-ground CPDLC events as the System's Air Traffic Controller. The controller workstation receives its configuration from the System Manager. The configuration data includes a script for each aircraft that will communicate with the controller. The controller application builds and transmits CM and CPDLC messages to each aircraft at the scripted time. It also responds to CM and CPDLC messages received from aircraft. Transmitted and received CM and CPDLC messages are encoded/decoded, time-stamped, and stored locally for later reduction.

Human-Interactive Aircraft

The human-interactive aircraft application is resident on one of the workstations and provides a graphical user interface that emulates a generic Master Communications Display Unit (MCDU) (Figure 3). The MCDU facilitates "human in the

loop” pilot test participation. The application builds and transmits CM and CPDLC messages in response to user inputs via the MCDU. Each message is stored locally with an appropriate time-stamp. Received CM and CPDLC messages are decoded and displayed on the MCDU as well as time-stamped and stored. If a received message requires a response, the user is presented with a list of responses appropriate for that particular message from which to choose.

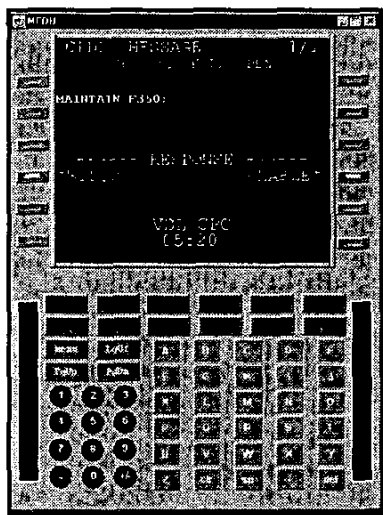

Figure 3. Aircraft Display

Human-Interactive Controller

The human-interactive controller application provides a graphical user interface that emulates a generic ATC workstation display for both the CM and CPDLC applications (Figure 4). As its name suggests, the controller display facilitates “human in the loop” testing. The application builds and transmits CM and CPDLC messages in response to user inputs via the controller display. Each message is stored locally with an appropriate time-stamp. Received CM and CPDLC messages are decoded and displayed as well as time-stamped and stored locally. If a received message requires a response, the user is presented with appropriate responses from which to choose.

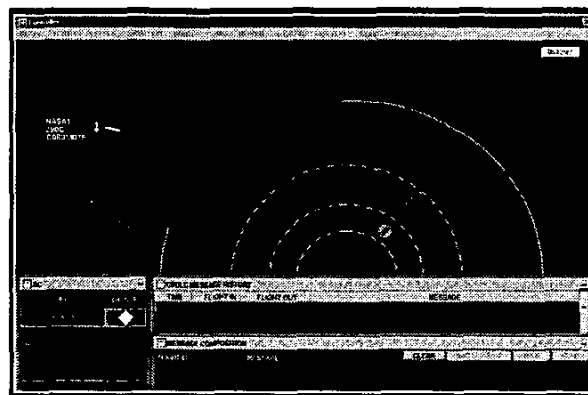

Figure 4. Controller Display

System Manager

The System Manager provides the means to develop a library of scripts and experiments. The user develops a script by entering the time and CPDLC declarative and request messages that are to originate from the aircraft and controller. The user prepares an experiment configuration by assigning aircraft and controllers to workstations plus assigning scripts and starting times to aircraft. Each aircraft and controller is assigned a unique address that conforms to the ATN standards.

When the user starts an experiment, the System Manager distributes the aircraft and controller configurations to the assigned workstations. The System Manager displays the progress of each aircraft in the execution of its assigned script. Performance statistics are collected by the aircraft and controller applications during the experiment and transmitted for display at the System Manager.

Once the experiment has been completed, all of the data collected by each aircraft and controller is sent to the System Manager for storage and report generation. Numerous data reports can be prepared to analyze the performance of the System during the experiment.

Performance Measurement

The Testbed provides a means to measure the end-to-end delay associated with using ATN applications over various subnetworks. “End-to-end” delay in this context starts when an ATC

controller sends a message and the pilot receives it. Or, it starts when the pilot sends a message and the controller receives it. The applications are CM and CPDLC. The air-ground subnetwork that is supporting CPDLC Build I is based on the VDL Mode 2 protocol.

The Testbed can provide an insight into the number of data link equipped aircraft that can operate safely on a single frequency. The FAA's transfer delay requirements for CPDLC are shown in Table 1,² while the mean delay budget for the CPDLC Build IA system is shown in Figure 5.³ The mean delay requirement in the en route domain is 10 seconds, while the budget used in developing the CPDLC IA system is 8.6 seconds (mean). The budget component allocated to air-ground communications is three (3) seconds.

GRC can perform experiments using the Testbed to estimate the number of aircraft that can operate on a single frequency while satisfying the delay requirements. The Testbed can generate the data link messages associated with up to 160 separate aircraft flying realistic flight profiles. The user via a scripting mechanism defines the flight profiles. The results of the experiments can be compared to the FAA's delay requirements.

Table 1. CPDLC Transfer Delay Requirements

Domain	Mean End-to-End Transfer Delay	95% End-to-End Transfer Delay	99.996% End-to-End Transfer Delay
Terminal	5 sec	8 sec	12.5 sec
En Route	10 sec	15 sec	22 sec

² Initial Requirements Document for Controller Pilot Data Link Communications (CPDLC) Service, Federal Aviation Administration, June 22, 1998

³ Draft FAA Specification for Controller Pilot Data Link Communications Build-IA (CPDLC-IA), Federal Aviation Administration, January 5, 2000

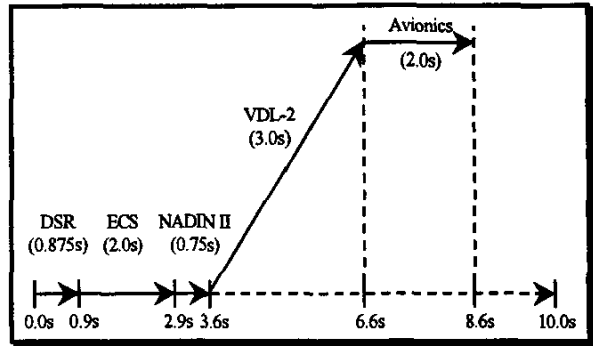

Figure 5. Mean Transfer Delay Time Budgets

VDL Mode 2 Communications Equipment

The next evolutionary step in developing the VAC Testbed was the addition of a VHF Digital Link (VDL) Mode 2 communications capability. A SITA VDL Mode 2 ground station was incorporated into the Testbed along with four aircraft radios and software emulations of a Communications Management Unit (CMU). Figure 6 shows the interfaces between the original Testbed equipment and the SITA VDL Mode 2 communications equipment.

Surveillance Applications

ADS-B

The addition of Automatic Dependent Surveillance - Broadcast (ADS-B) to the Testbed provides the capability to study a new surveillance technique that is being implemented in the NAS. An ADS-B aircraft broadcasts information about itself on a periodic basis. The period can be as short as once per second. The information includes the aircraft's address, identification, location, speed, and equipment. The VAC Testbed implementation⁴ includes the Mode Status Report and State Vector messages as defined in the RTCA ADS-B Minimum Aviation System Performance Standards (MASPS).⁵

⁴ System Specification to NASA GRC for the Virtual Aircraft and Controller - Build C, Version 2.0, Computer Networks & Software, Inc., July 8, 2003

⁵ DO-242A, Minimum Aviation System Performance Standards for Automatic Dependent Surveillance Broadcast (ADS-B), RTCA, June 25, 2002.

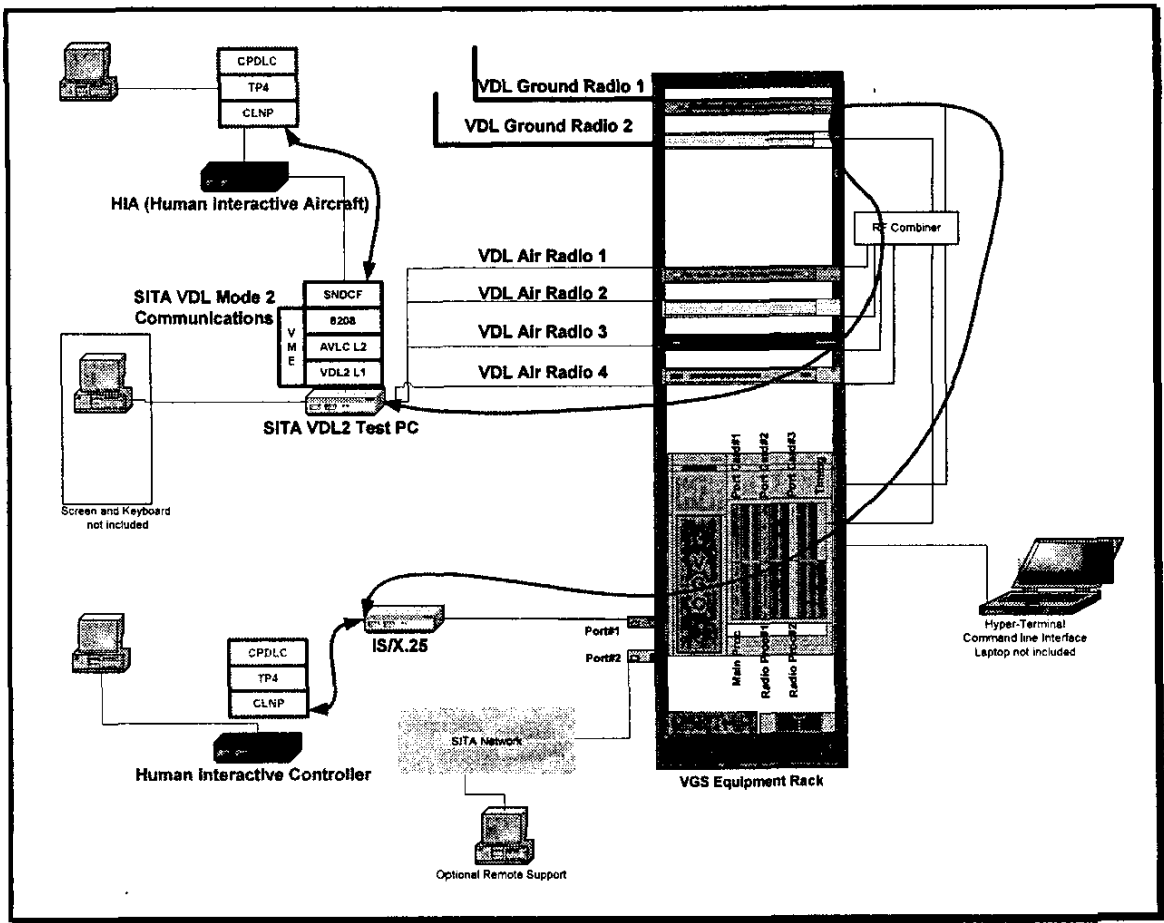

Figure 6. VDL Mode 2 Communications Equipment

When an ADS-B aircraft transmits a Mode Status Report or a State Vector message, similarly equipped aircraft receive information about the aircraft. The receiving aircraft can use the State Vector message to display the aircraft's location on a Cockpit Display of Traffic Information (CDTI). As a result, the receiving aircraft can "see" the sending aircraft's location in relation to its own, even when the climate does not let the pilot see it visually.

ATC systems can also receive the ADS-B messages and use the data to supplement the surveillance data acquired from radars.

TIS-B

The Testbed's Traffic Information Service - Broadcast (TIS-B) capability can be used to study a new surveillance capability that is being implemented in the NAS. In contrast to ADS-B's aircraft-to-aircraft transmissions, TIS-B's aircraft location data is broadcast from the ground by the ATC system.

Aircraft data available to the ATC system comes from ground-based surveillance radars and ADS-B reports. The data from multiple reports is correlated and the best surveillance data available is broadcast to all aircraft in the area.

As an approach to control costs and reduce the quantity of equipment on an aircraft, TIS-B

messages are transmitted on the same frequency as ADS-B. In addition, the avionics that receives ADS-B messages should be able to process TIS-B messages.

Each TIS-B message is a report about a single aircraft. The message is referred to as a Target Report. A message will include the target's identification, location, and speed. The report will also include an indication as to the accuracy of the location data. The VAC Testbed implements the Target Report format defined in the RTCA TIS-B Minimum Aviation System Performance Standards (MASPS), DO-286.

ADS-B & TIS-B Communications Architecture

The communications architecture for the ADS-B implementation is shown in Figure 7. The architecture includes Autonomous and Human

Interactive Aircraft (AA and HIA), Autonomous and Human Interactive Controllers (AC and HIC), and a System Manager. The protocols for exchanging ADS-B and TIS-B messages over the Testbed Local Area Networks (LANs) are Ethernet (IEEE 802.3), Internet Protocol (IP) and User Datagram Protocol (UDP).

The routers are connected to communications systems for transmitting the ADS-B and TIS-B messages. Figure 7 shows satellites being used as the communications medium.

As mentioned earlier, the VAC Testbed can emulate the communications associated with up to 160 autonomous aircraft. Each of those aircraft will be reported in a TIS-B Target Report. A subset of the 160 aircraft can emulate the broadcast of ADS-B messages. The experimenter can designate up to 40 aircraft as having an ADS-B capability.

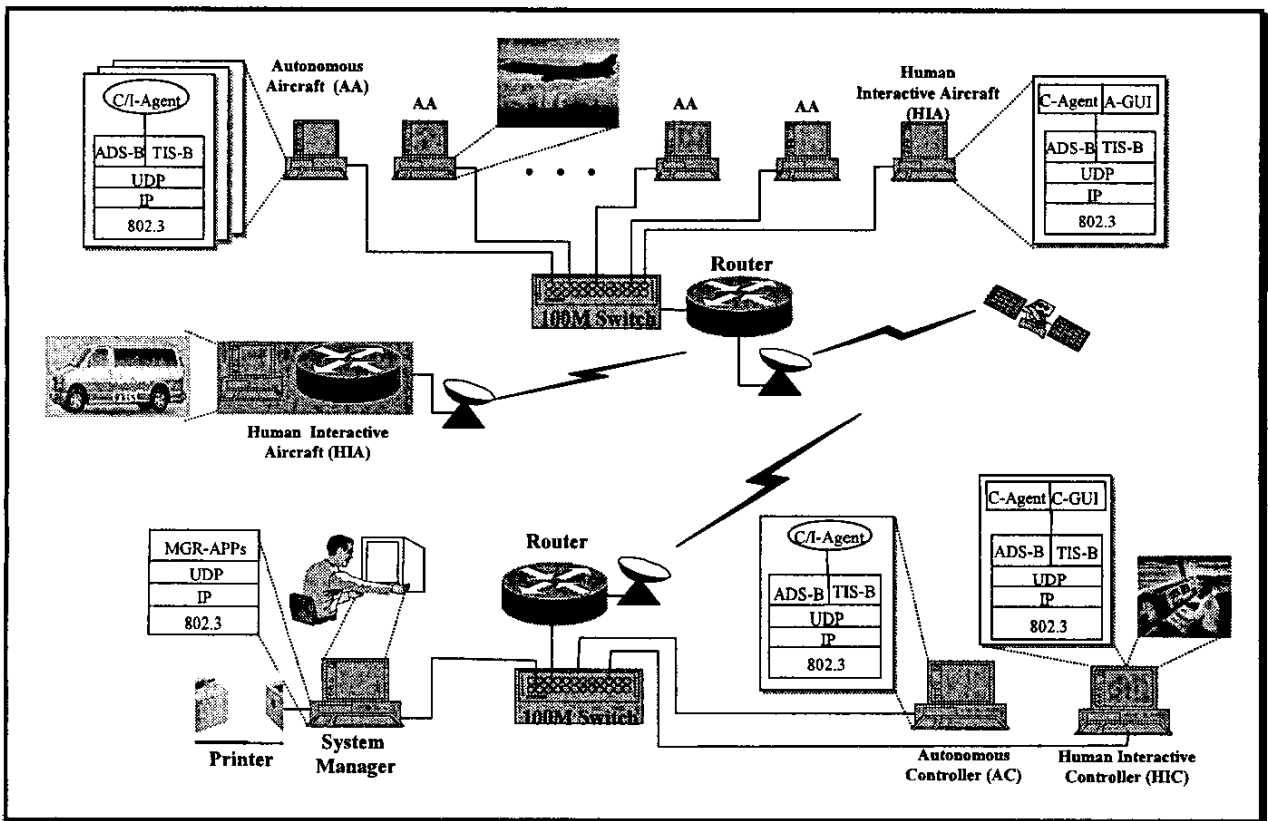

Figure 7. ADS-B/TIS-B Communications Architecture

Radio Frequency Environment

The impact of different modulation schemes, antenna equipment, and adjacent radio channel interference effects upon data link communications is a concern of NASA.

The U.S. Military is also concerned about the effects of the radio environment for war fighting. As a result, the United States Air Force and Navy Avionics Test Commands have developed the Joint Communication Simulator (JCS) to provide for the simulation of large-scale emitter environments.

With the future need to emulate an active RF environment, the VAC Testbed may be modified to include the principles and capabilities that are

available in the Joint Communications Simulator. (Figure 8)

This system supports different waveforms, frequencies and power levels plus provides for communications delays. With these improved capabilities, the Testbed should be able to model any proposed communications system and determine system capabilities before building prototypes. This can increase the efficiency and safety of future systems.

This enhancement will also be able to model the interactions between voice and data circuits. This will assist in the proper placement of transmitters and channel selection for the aviation radio frequency environment.

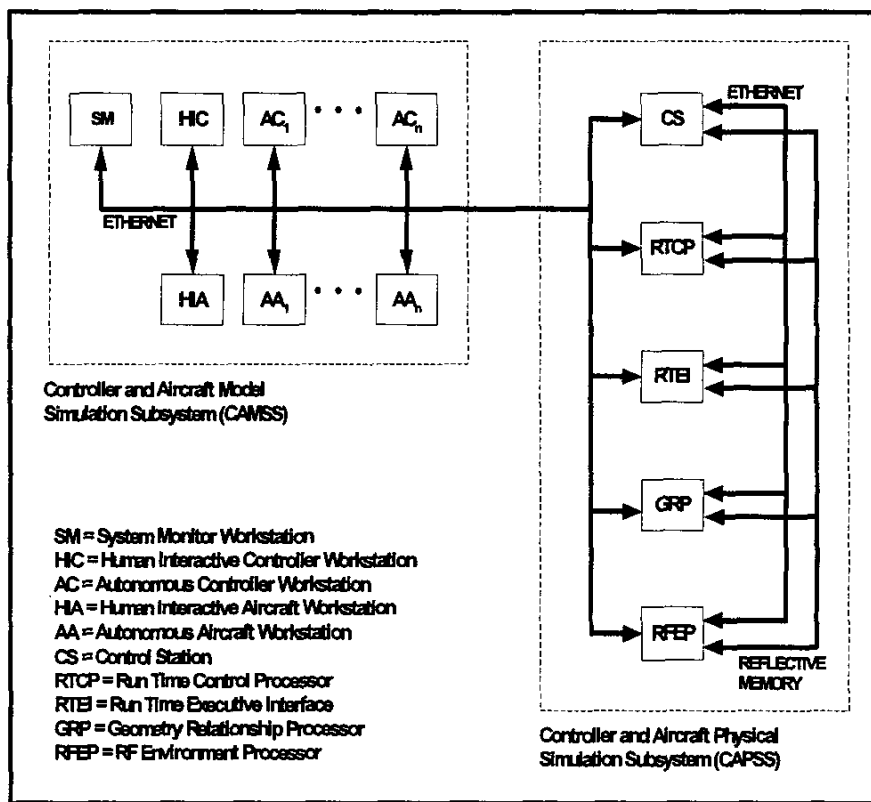

Figure 8. VAC Testbed with the JCS

Summary

GRC's VAC Testbed provides the capability to study the impact of data link traffic loads from various applications on the NAS communications infrastructure. The Testbed is evolving and provides a means of generating and observing the performance of large-scale aeronautical data link communications using different subnetworks.

End-to-end ATN message (CM and CPDLC) emulation is provided through script-driven, departure-through-arrival scenarios that can support a full range of communications test activities. The capability to use up to 160 aircraft in an experiment coupled with the Testbed's performance measurements provides the means to assess the number of aircraft that a subnetwork can support while meeting the FAA's performance goals. The addition of VDL Mode 2 subnetwork communications systems adds another dimension of realism to the analysis toolset.

The implementation of an ADS-B and TIS-B message emulation capability supports studies on new surveillance applications that have recently been added to the NAS.

With the addition of the capabilities of the JCS the Testbed will be able to emulate any communication system that may be deployed. The performance will be quantified and deficiencies will be identified so that they may be mitigated upon deployment.

References

- [1] Computer Networks & Software, Inc., September 29, 2000, Global Aviation Communications Test & System Emulation Facility (GACTSEF) System Engineering Definition Study Report.
- [2] International Civil Aviation Organization, 1999, Manual of Technical Provisions for the Aeronautical Telecommunication Network (ATN), ICAO DOC 9705/AN956, 2nd Edition.
- [3] Federal Aviation Administration, June 22, 1998, Initial Requirements Document for Controller Pilot Data Link Communications (CPDLC) Service.
- [4] Federal Aviation Administration, January 5, 2000, FAA Specification for Controller Pilot Data Link Communications Build-IA (CPDLC-IA), Draft.
- [5] Computer Networks & Software, Inc., July 8, 2003, System Specification to NASA GRC for the Virtual Aircraft and Controller - Build C, Version 2.0.
- [6] RTCA, June 25, 2002, Minimum Aviation System Performance Standards for Automatic Dependent Surveillance Broadcast (ADS-B), DO-242A.
- [7] RTCA, April 10, 2003, Minimum Aviation System Performance Standards (MASPS) for Traffic Information Service - Broadcast (TIS-B), DO-286.

Email Addresses

Charles Sheeh, Charles.J.Sheeh@nasa.gov

Tom Mulkerin , Tom.Mulkerin@Mulkerin.com