

# A PROPOSAL FOR A RADAR SYSTEM COMPUTER COMMUNICATION ARCHITECTURE

*Louis J. Bottino, Federal Aviation Administration William J. Hughes Technical Center*

## Abstract

The objective of this paper is to describe a computer communication architecture for an Air Space Management System (ASMS). This system is proposed for the Federal Aviation Administration William J. Hughes Technical Center (FAATC).<sup>\*</sup> Three transmission mediums will be used in the transfer and exchange of radar information.

The methodology on computer/data communications and computer architecture will be discussed and analyzed. Geography, system topology and other system parameters have determined the computer network architecture best suited for the job. At the conclusion of this proposal a discussion of what would be accomplished by implementing this design, and lessons learned in researching this proposal will be presented.

## Introduction & Background

The number of aircraft flying over the Philadelphia, Delaware Valley and South Jersey areas has increased over the past few years according to air traffic controllers and officials at the FAA Technical Center. This increased air traffic comes from the number of commercial airline flights in and out of Philadelphia International Airport, the smaller municipal airports in the Delaware Valley and the commercial aircraft out of Atlantic City International Airport. Surveillance could be improved in this area, since it is in this airspace that the FAA conducts flight tests for research and development of new avionics systems. These flight tests are performed in FAA aircraft which are flown in the experimental category.

---

<sup>\*</sup> This proposal was created as a Computer Engineering course requirement. It does not represent a real plan to construct or alter the existing surveillance systems in the Atlantic City airspace. However the computer communications network design is based on real events in the procurement of a radar system. Some of the technical aspects of this proposal may appear dated.

In an effort to better surveillance and safety, a comprehensive Air Traffic Control (ATC) system called the ASMS is being proposed to the FAA Technical Center. The goal of the ASMS is to increase the surveillance in a growing airspace and allow continuing flight test operations by the Technical Center. The safety of the airspace would be enhanced with this system since air traffic controllers would have a clearer and expanded view of the surrounding area. FAA aircraft flown during research and development test flights could be cautioned to not interfere with commercial and general aviation.

The present ground-based ATC system in the area utilizes a signal (live radar feeds) received from Eastern Region in New York. The Technical Center has no control over these radar feeds because they are managed and maintained by Eastern Region. Security concerns prevent the Center from directly receiving the transmission from Eastern Region. Instead the signal, which originates at Riverhead Long Island, is received at the Technical Center via the Naval Air Systems Command Station in Oceania, Virginia. Ground-based radar stations, modems and co-axial cables are used for data communications. As a Naval Radar Installation, the Naval Air Systems Command Station serves the aviation community by providing an airspace surveillance service to commercial and government agencies.

Using the same technologies, a proposal to increase the geographical coverage and for the Technical Center to purchase its own system is presented. Again the Naval Air Systems Command Station in Oceania, Virginia is instrumental in transmitting the airspace scenarios. This time the Mid-Atlantic airspace is included with the Delaware Valley, and the New Jersey Air National Guard (ANG) Base at Pomona. In this scenario the ANG base will have its own stationary radar system, and will transmit a microwave signal to the Naval Air Systems Command Station in Oceania. Oceania will transmit the radar signal to a satellite. The

satellite's radar signal will then be received at a ground-based radar station at the Technical Center, a short distance from the FAA control tower. Using modems and coaxial cables provided by AT&T the radar signal will be brought to the new radar computer system in the FAA control tower. The same safety concerns that conceived the present radar network produced this proposal for the FAA Technical Center. When a study of the latest air traffic patterns in the area was reviewed the result was an expensive but beneficial solution. If the proposal is accepted the procurement, implementation and deployment timeframe would be approximately three to five years. This would include the operational test and evaluation of the entire computer communication network and radar system. (In addition all ATC systems require flight plan data and surveillance information. Therefore after a successful operational test of the entire system a connection to the National Airspace System (NAS) to provide this flight data processing may be possible.)

A discussion of the ASMS follows with an emphasis on Computer / Data Communications and Computer Architecture. The proposed ASMS will be a new radar system based on similar technologies to the old. An attempt to use Open Systems Architectures in both Computer and Satellite communications will be made. The system topology and mission goals have defined the Computer and Satellite Network Architecture best suited for the Center ASMS.

## Computer System Description

### *The Proposed FAA Technical Center's Air Space Management System*

Once operational the FAA Technical Center's ASMS would enable FAA pilots to continue research and development flight tests in an improved environment. The radar data generated from Riverhead would be compatible with the new system proposal.

The proposed baseline ASMS to be located at the FAA control tower consists of one Central Processor Unit (CPU), a computer operator workstation (System Terminal), a modem, a line printer and two situation display consoles with 22

inch cathode-ray tubes (CRTs).<sup>1</sup> (See Figure 1.)

Computer communications between the Technical Center and the ANG base would involve precise signal management and conditioning from the radar processed at the Naval Air Systems Command Station in Oceania, Virginia. The microwave signal will be transmitted from the ANG base in Pomona, N.J. and received at the Naval Air Systems Command Station, Air Route Surveillance Radar (ARSR). In Virginia, a Primary and Secondary Plot Extractor System Digitizer located in a single rack interfaces with the ARSR. In the digitizer, data from the surrounding Atlantic Coastline is encapsulated and processed. After digital / radar signal processing, messages are encoded and transmitted to the Western Union Communications Satellite, they are then re-transmitted to a ground-based radar at the Technical Center in the vicinity of the FAA control tower. Once the signal arrives at the control tower the information is transformed into radar messages in CD-2 Format by the Concurrent Computer Central Processor Unit (CPU). A Programmable Line Interface Module (PLIM) forwards the decoded signal to each situation display (radar console) as CD-2 Formatted radar message units for analysis.

Data and telecommunications use 201-C modems when required with a normal transmission baud rate of 2400 bits-per-second (bps). At the control tower link a one-way simplex mode is used where three modems are multiplexed for redundancy and at least one channel is 4800 baud. The Omnimode 96 modem system used is a software-controlled device manufactured by Racal-Milgo.<sup>2</sup>

The system described has an excellent track record of meeting all mission-related test environment requirements from the CPU to the data terminal (Situation Display). In addition to the modulation / demodulation of communication signals, the Omnimode 96 system can perform specialized testing and monitoring of other modems in the network and their communication lines.

<sup>1</sup> "Airspace Management System", United Technologies Corporation document dated October 17, 1987.

<sup>2</sup> "Omnimode 96, Preliminary Reference Manual" by RACAL-MILGO INFORMATION SYSTEMS, November, 1983, pg. 1-1

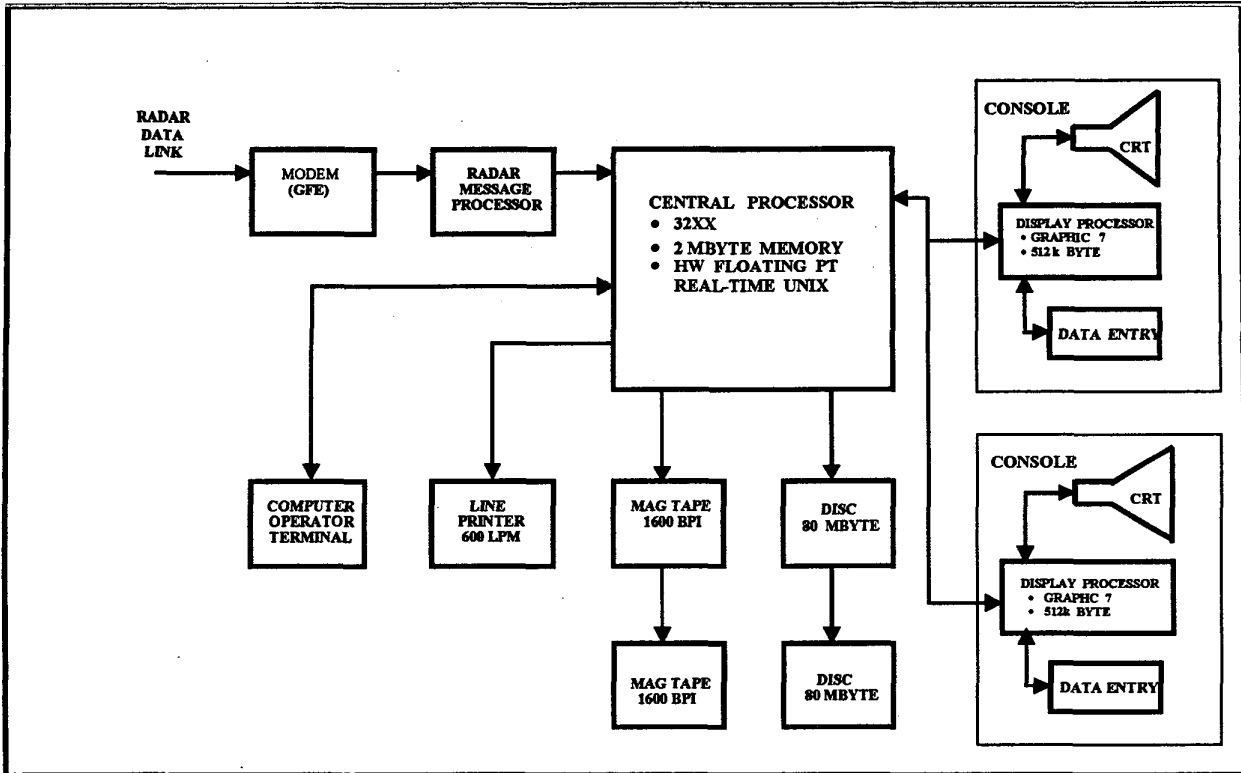

Figure 1. Block Diagram of the Baseline FAA Air Space Management System to be Located in the FAA Control Tower at the FAA Technical Center in Pomona, New Jersey.

Restrictions on hardware-based technology has been eliminated by efficiently using transmission lines and equipment. The system is built for flexibility, uses 4-wire lines for transmission and operates with either constant or switched carrier in a dedicated line or dial backup mode.

The proposed specifications and equipment capacities have been specially designed and created to meet the needs of the Center with its airspace requirements. Detailed hardware and software considerations have resulted in situation displays with clear radar graphics, reliable processors and high resolution screen displays. Topographical coordinates and complex geographical data information has been carefully encoded in the system software to make this possible.

Operationally the Concurrent Computer utilizes a non-standard UNIX-like operating system. The system will simultaneously receive and process inputs from data communication modems. At least one input message per second per operator and at

least 12 messages per minute is processed without loss of information. (See Figure 2.)<sup>3</sup>

The system is also capable of accepting up to 100 radar messages among a typical mix of message types every second without loss of data. Every 4 second period 1200 radar plots are capable of being processed and displayed. A minimum of 200 tracks with related data are able to be tracked at one time and four plot filter maps are able to be maintained by the air traffic controller. This information is supplied by Oceania via the Western Union Communications Satellite. Expansion with additional radar consoles will be considered and is a viable possibility. The software provided should enable each radar console to maintain all data within the console's memory. Using an appropriate switch command a 4 second radar frame displays aircraft histories plus mode 1, 2, 3 and mode C codes.

<sup>3</sup> Specifications for Radar System, Sanders-Defense and Information Systems Division, 1983 leaflet.

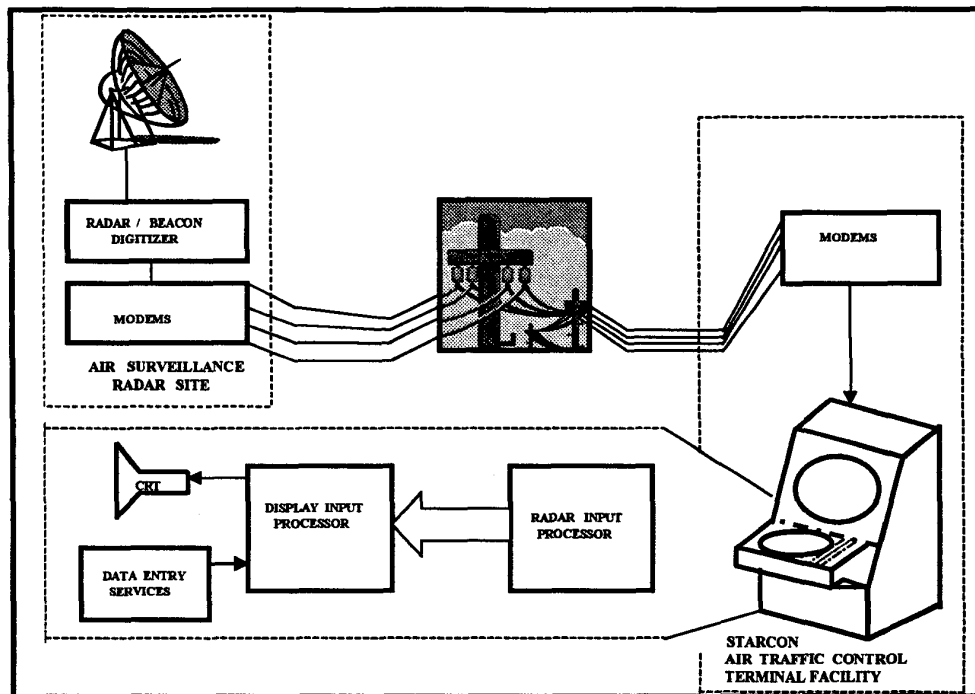

Figure 2. Closed-Loop Configuration of ASMS Showing Radar Repeating System at the Offsite Location Receiving Digitized Signal Information. Note the Coaxial Cables and Modems in the Control Tower.

**Computer Configuration Management**

Four functional areas will make-up the proposed ASMS located in the FAA Control Tower:

- Data Processing and Peripherals Functional Area
- Display Console Functional Area
- Operational Computer Program Functional Area
- Support Computer Program Functional Area

The Computer Architecture structure and protocols to be discussed define the Operational Computer and Support Computer Program Functional areas listed above. Efficiency concerns, service quality and transmission parameters have all been factored into the computer architecture. Protocol parameters associated with syntax, semantics and timing have also been included in the protocol design.

Symmetrical protocols could be used for this system if the Open Systems Interconnection (OSI) reference model is followed. (See Figure 3.)<sup>4</sup> These protocols involve compatible peer entities, and are considered non-standard if they are specially designed for a Concurrent Computer System.

Generally all types of protocols provide data formatting , various signal levels for data and control , flow control , synchronization, and appropriate sequencing for data to be exchanged. Two networks will offer two-way communication for any specific application(s) if they use the same protocol.<sup>5</sup>

<sup>4</sup> Stallings , William, "Data and Computer Communications", 1985, pg. 392.

<sup>5</sup> Chen, C.H., "Computer Engineering Handbook," 1992, Chapter 20, .20.20.

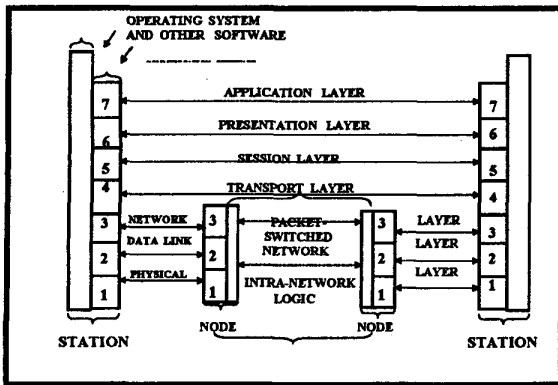

**Figure 3. The OSI Reference Model for Data Communication Protocols**

The OSI Model shown in Figure 3 is given as an example of a computer architecture philosophy. It should be noted that the International Organization for Standardization (ISO) developed the OSI model as a conceptual framework for software engineers to develop "open networks". For the non-standard, UNIX-like operating system Digital Network Architecture (DNA), which is a derivation from the Department of Defense (DOD) Protocol Architecture (DPA), is selected as the most suitable computer architecture to provide data communications between the FAA Technical Center and Oceania, Virginia. One primary advantage of the DPA approach is that it is less restrictive than the OSI model. An example of this is an entity may directly use the services of a hierarchially lower entity, even if it is not in an adjacent layer.<sup>6</sup>

This short description has introduced the computer architecture approach used so the data communication protocols can be discussed. Based on hardware and software system requirements the most efficient and accommodating system design will be constructed.

## Proposal for a System Configuration

### *Computer Communication Network and Architecture*

Some hardware and software surveillance components of this ASMS shall resemble the

<sup>6</sup> Stallings, William, "Data and Computer Communications", 1985, pg.396.

ground-based radar system located at Riverhead, Long Island. The computer communications architecture proposed corresponds to the Advanced Research Project Agency Network or ARPANET configuration. (The combined ARPANET and DOD configurations have since evolved into the present day Internet) Dependability, reliability, and survivability were the critical operational parameters (COPs) studied and the reasons why this type of architecture was suggested. Also resource sharing in a distributed environment and the ability to provide decentralized and distributed networking capability were other factors taken into consideration.<sup>7</sup>

The four DNA-defined layers are :

- Data Link Layer
- Transport Layer
- Network Services Protocol, and
- Network Application

Physical and data link layers permit RS-232-C interfaces and enable dependable link-to-link computer communications. The transport layer, while providing a reliable transparent transfer of data information between the Tech Center ground-based radar station and the control tower, provides end-to-end error recovery and flow control. This feature has a redundancy characteristic not built in the communication exchange between Riverhead and the FAA control tower. Routing, congestion control, packet lifetime control and transport initialization are other features the transport layer controls. The Network Services Protocol (NSP) acts as a safeguard against unreliable physical transmission links. The Network Applications layer oversees high-level supplied functions in DNA. Remote file access, file transfer and remote system load are other operations controlled in this layer.<sup>8</sup>

A bridge configuration is used to support a simplified gateway to connect homogeneous networks. With the bridge the Tech Center ground-based radar station and the control tower computer communications are assured reliability, performance, security, convenience and

<sup>7</sup> Stallings, William, "Data and Computer Communications", 1985, pg. 247.

<sup>8</sup> Ibid., pg. 405.

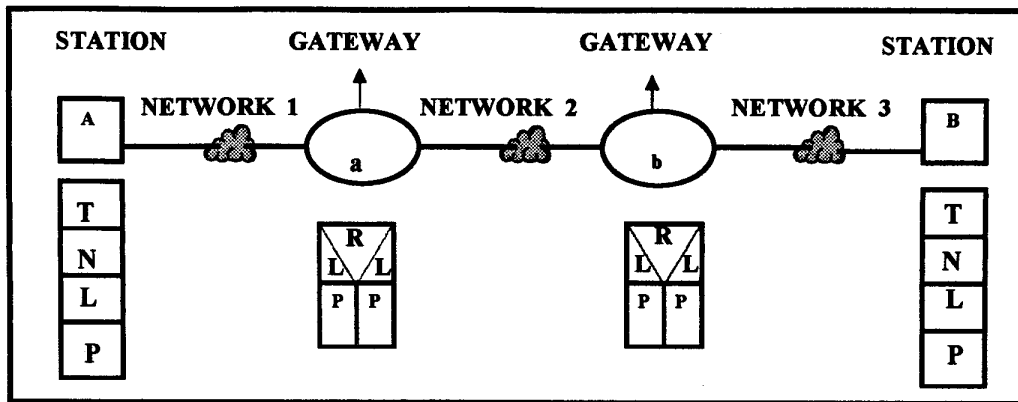

Figure 4. Bridge Architecture Configuration to be used at the FAA Control Tower in Pomona, N.J. and at Oceania, VA.

geographical coverage.<sup>9</sup> Since multiple situation display consoles are recommended in this proposal the bridge configuration shown in Figure 4 can deliver the desired result.<sup>10,11</sup>

To explain the operations of the bridge before and after the Western Union satellite, consider the communications link at the FAA control tower. First, Figure 4 identifies a gateway as a single system which implements protocols appropriately to two or (three) networks. Assuming the control tower has a situation display console representing one network, two or three situation display consoles or work stations can represent two or three networks. Station A can establish a transport connection with gateway a and each can use the network access protocols for network 1 (N1, L1, P1). Gateway a must use another transport connection to gateway b. A relay mechanism is also utilized to convert transport protocols from one network to another. This relay function "R" actually splices the networks together at the link level.<sup>12</sup>

Each bridge would maintain status information on other bridges, together with the cost and number of network hops required to reach each network.

(See Figure 5 for bridge operation illustration).<sup>13</sup> This information can be updated by periodic exchanges of information by additional bridges. This process allows each bridge to perform a dynamic routing function. A control mechanism manages packet buffers in each bridge to overcome congestion. When information saturation occurs, the bridge would give precedence to enroute packets over new packets just entering an attached proposed local network. This preserves the line bandwidth and processing time the enroute packet has already made.<sup>14</sup>

With the bridge protocol structure in place other DOD type transport mechanisms are used to transfer the digitized radar signal. The ISO, which is the issuing agency for communication standards for protocols, will be consulted to recommend additional protocol service designs.<sup>15</sup> Their recommendations are expected to be both connection-oriented and connectionless-oriented. The connectionless-oriented service User Datagram Protocol (UDP) is suggested for this proposal to support the developed links between the Tech Center ground-based radar station in Pomona and

<sup>9</sup> Ibid., pg. 445.

<sup>10</sup> Currently similar networks would use a router configuration to communicate and exchange information. Also a repeater would be used to amplify the signal. During the time this proposal was made a bridge architecture configuration was suggested.

<sup>11</sup> Ibid., pg. 443.

<sup>12</sup> Ibid., pg. 442.

<sup>13</sup> Ibid., pg. 445.

<sup>14</sup> Ibid., pg. 446.

<sup>15</sup> Previously the Defense Communications Agency (DCA) had control over all DOD type protocols. Today the ISO publishes standards on protocols and the Internet Engineering Task Force (IETF) publishes Request for Comments (RFCs) which govern standards for most DOD type protocols.

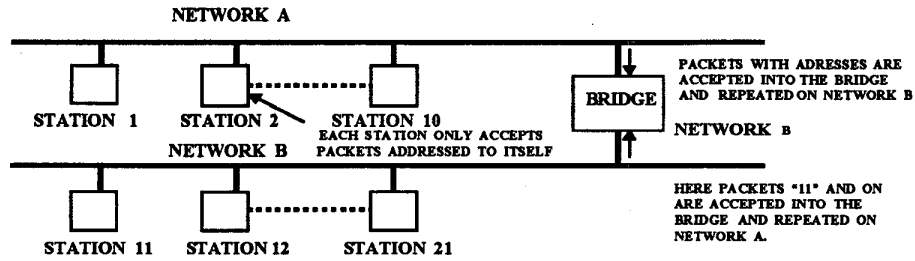

Figure 5. Operation of Bridge Configuration in Pomona , N. J. and the Control Tower

the control tower. Though this transport-level datagram service is not as reliable as the Transmission Control Protocol (TCP) because delivery and duplicate protections are not-guaranteed, this service does reduce overhead and is suited for this connection-link.<sup>16</sup> (See Figure 6.)<sup>17</sup>

										1 1 1 1 2 2 2 2 2 2 2 2 3 3																				
1	2	3	4	5	6	7	8	9	0	1	2	3	4	5	6	7	8	9	0	1	2	3	4	5	6	7	8	9	0	1
SOURCE PORT															DESTINATION PORT															
LENGTH															CHECKSUM															

Figure 6. DOD User Datagram Protocol Header Formats are Shown Above.

Two major microwave links depend on satellite communications for the successful implementation and operation of the proposed facility. In order for the Western Union satellite to operate effectively it must have a geosynchronous orbit. This means the satellite is required to remain stationary with respect to its position over the earth. To remain stationary the satellite must have a period of rotation equal to the period of the earth's rotation.

### Satellite Communication Network and Architecture

Included in the ATC expansion is a satellite communications system. A Western Union WESTCOM<sup>18</sup> satellite located approximately

<sup>16</sup> Ibid . , pg. 507.

<sup>17</sup> Ibid . , pg. 506.

<sup>18</sup> Western Union's Brand Name Trademark.

22,300 miles above the earth shall be equidistant from Virginia and Pomona, New Jersey. The satellite will receive and transmit the radar data to a ground-based radar station at the Technical Center.

The reliable and efficient reception and transmission of the radar signal by the Western Union Satellite is of primary concern. To this end the satellite network architecture constructed should not be compromising or built with trade-off studies in mind. The Western Union Satellite utilizes a Satellite Communication Controller (SCC) located at each earth reference station (ground-based radar station) This device performs the signal processing at each earth reference station and provides digital signal conversion along with adequate signal conditioning and management. Time Division Multiple Access (TDMA) is selected as the type of Medium Access Control (MAC) Protocol used at each earth reference station instead of Frequency Division Multiple Access (FDMA).<sup>19</sup>

In FDMA each earth station is assigned a different carrier frequency or group of frequencies on a fixed basis, whereas TDMA uses a fixed assignment technique and transmission is in the form of a series of frames, each of which is divided into a number of slots.<sup>20</sup> The advantages of this protocol are threefold. First, the cost of digital components are reasonable. Secondly, the digital

<sup>19</sup> Both transmission and switching mechanisms, (not voice , but just data information) will be digital forming an integration of Time Division Multiplexing (TDM) and Pulse Code Modulation (PCM).

<sup>20</sup> Stallings, William, "Data and Computer Communications", 1985, pg. 307.

signal processing is easily performed and thirdly TDMA is more efficient because of the lack of inter-modulation noise.

Another protocol technique in the same family as TDMA is called Demand Assignment Multiple Access (DAMA). DAMA is used together with TDMA to improve transmission efficiency. To establish a full-duplex link between two earth reference stations a pair of sub-channels can be dynamically assigned on demand. This can be considered a form of circuit-switching.<sup>21</sup>

There are five transponders in the Western Union Satellite which will enable the radar signal to be shared by more than one earth reference, if necessary. A propagation delay of about 240 to 300 ms will be experienced from the transmission of one earth reference station to the reception by another.<sup>22</sup> In addition an earth-satellite-earth propagation delay of about one-fourth of a second will occur after each transmission. Frequency separation will be of paramount importance to avoid interference in reception and transmission. Typically a satellite will receive transmissions on one frequency band (up-link), amplify with (analog transmission) or repeat the signal with (digital transmission) and finally transmit on another frequency (down-link). For the Westcom satellite proposal the Oceania ground station to satellite transmission is 12,000 MHz or (12 GHz) while the satellite to ground transmission will be 14,000 MHz or (14 GHz). The capacity bandwidth is expected to be about 500 MHz, which would have the potential for 24 to 28 channels. One disadvantage here is that attenuation can pose a problem at these frequencies and overall signal distortion can be increased.<sup>23</sup>

One advantage of these higher frequencies is a possible higher data rate. As part of the signal processing routine, before data transmission to the Westcom satellite is completed, analog signals are converted to a digitized form using a CODEC mechanism (CODER-DECODER Mechanism).

In the two earth reference stations located at Oceania and the Tech Center ground-based radar station, there is a data communications link which interfaces the Radio Frequency Terminal (RFT), Burst Modem, SCC and Port Adaptor. (See Figure 7). The set-up at the control tower also includes a Primary and Secondary Plot Extractor System Digitizer. So when the radar signal is transmitted from the satellite to the radar dish at the reference station, besides the signal conditioning at the reference station, the signal is digitized before being recovered at the control tower. The TDMA oriented communications between the station and the satellite is based on a 15 ms repeating time frame. Transmission is in the form of a series of frames, where each frame is divided into a number of slots and each slot is dedicated to a particular transmitter. The first part of the frame is the control field. Assignment is set and specified in units where the controller advises the earth station how many assignment fields it can have and by how much delay. The rest of the control field sets capacity and also space for user content. The capacity of one (1) channel shall be 720 k bits / 0.015 sec = 48 Mbps. This is typical for the TDMA protocol where data rates range from 10 Mbps to over 100 Mbps.<sup>24</sup>

Synchronization is incorporated in each 15 ms time frame. Rarely will collisions of information packets occur because timing is precise at the satellite and the reference earth station. Using geographic coordinates of the surrounding area the system software computes ranges. A short trial burst of data information is transmitted using these ranges, then once received at the reference station is compared with the initial target position. When the transit time is adjusted between the satellite and the earth station a Phase Lock Loop (PLL) oscillator locks in this transit time, the cycle is then established and the transit clock and reference clock are synchronized. Control and traffic messages are usually distinguishable. The CPU located at the reference station interfaces to a disc adaptor where codes are located and software is updated. Adaptors collect status information from the hardware and detect interrupts. This is after a maintenance device extracts information from the CPU so specifically controlled programs can be run. A supervisory

<sup>21</sup> Ibid., pg. 306.

<sup>22</sup> Ibid., pg. 59.

<sup>23</sup> For microwave frequency ranges, loss can be expressed as

$$L = 10 \log \left( \frac{4 \cdot \pi \cdot d}{\lambda} \right)^2 \text{ dB}$$

where d is the distance and  $\lambda$  is the wavelength.

<sup>24</sup> Ibid., pg. 307.



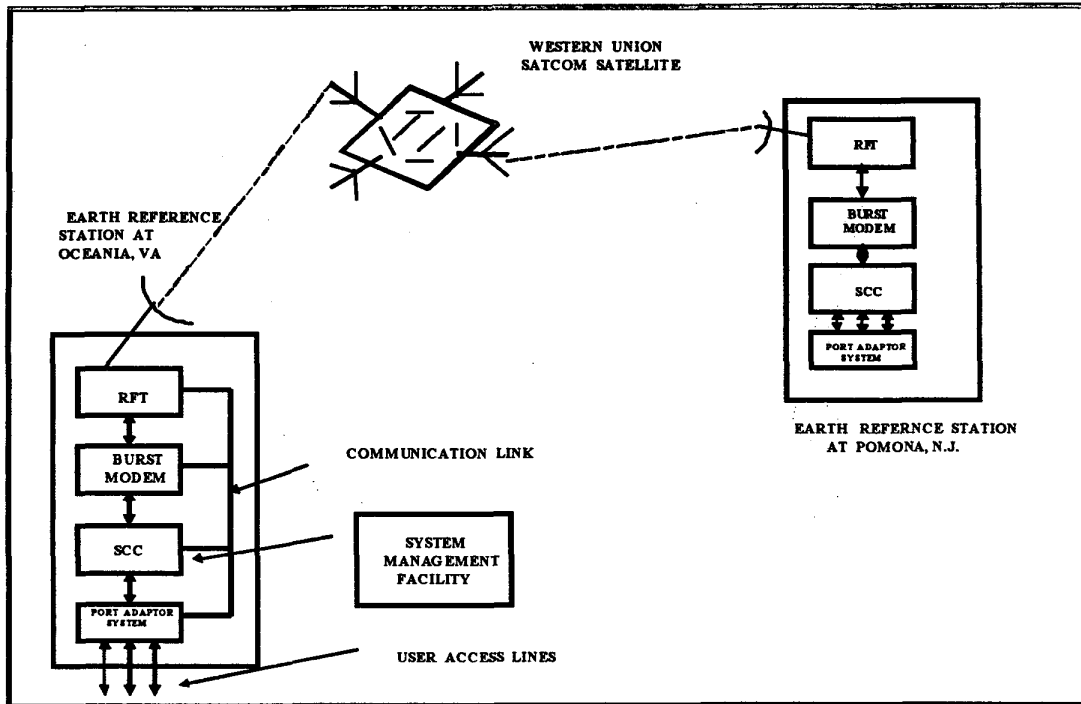

Figure 7. Satellite System Ground Station Configuration

protocol manages software execution and interrupt levels. This supervisory protocol also supports communication between tasks. All hardware adaptor interrupts will probably assume this configuration. (See Figure 8).

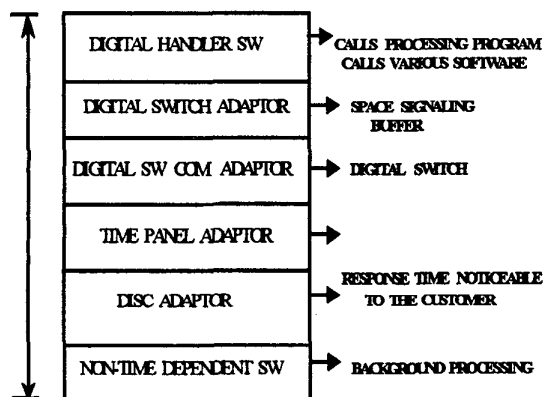

Figure 8. Hierarchy Setup of All Hardware Adaptor Interrupts.

During TDMA communications an individual earth station can utilize an up-link channel and forward a burst of data in the assigned time slot. The satellite then repeats all incoming transmissions. Earth stations are required to recognize not only which time slot to use for transmission, but also which time slot to use for reception. The satellite is also repeating the reference burst, where all stations are synchronized on the reception of that burst. Each repetitive time slot can be considered an independent sub-channel. So it can be used in any way that is deemed appropriate by the transmitting station. For instance, a form of packet switching can be accomplished by including an address field in each time slot. To correct any polling or contention issues<sup>25</sup> that may surface during transmission or reception a reservation protocol can be implemented with the DAMA-TDMA format. In a reservation protocol scheme, slots in future frames are reserved in a specific station.

<sup>25</sup> Contention issues surface when there is no central control exercised to determine whose turn it is. All stations contend for time on the network.

The SCC Functional Area is a critical component at each earth reference station. (A representation of this area can be seen in Figure 9).

This short description attempts to define the proposed computer / satellite architectural configurations and data communication protocols of the FAA Technical Center's ASMS. Based on hardware and software requirements the most

efficient and accommodating system design is constructed. It should be noted that security agreements with the military, and recommendations from standard organizations aside, numerous technical issues need to be resolved before the Technical Center's ASMS radar facility can become a reality.

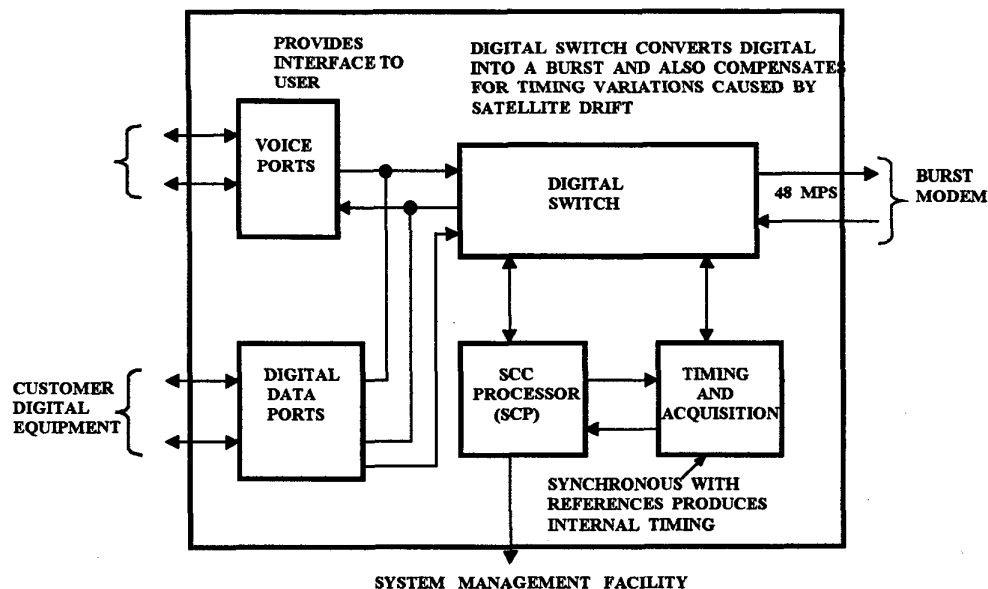

Figure 9. Satellite Communication Controller (SCC) Functional Areas. There is a Continuous Flow of Digital Signals Into the Digital Switch , Which is Converted from Digital to Burst By the Digital Switch.

## Feasibility and Justification

### *Rationale for Proposed System Configuration*

Studies have been conducted to develop the best suited computer communication network design. DNA was selected given the mission requirements, critical operational issues (COIs) and COPs . DNA is selected based on reliability, dependability and survivability factors once all critical performance criteria has been determined.

Using the bridge configuration the network can be partitioned into self-contained units. This averts the threat of a fault on a single network disabling all communications. Also network security is enhanced when certain portions of the network are isolated. And finally considering the number of links,

mediums and distances involved , the bridge architecture configuration agrees best with the widely separated network philosophy. Each computer /satellite communication protocol was selected for its open architecture versatility.

To conclude plans are underway by the FAA to consider and evaluate the mission critical need for an advanced satellite-navigation and data communications system. Such a system would enhance airway safety because air traffic controllers would have an broader, clearer, and cleaner view of the surrounding airspace with more exacting information.

In accordance with the preceding system descriptions the proposed computer communications for a radar system can be seen on the following page. (See Figure 10).

*System Diagram of the Proposed ASMS at the FAA Technical Center*

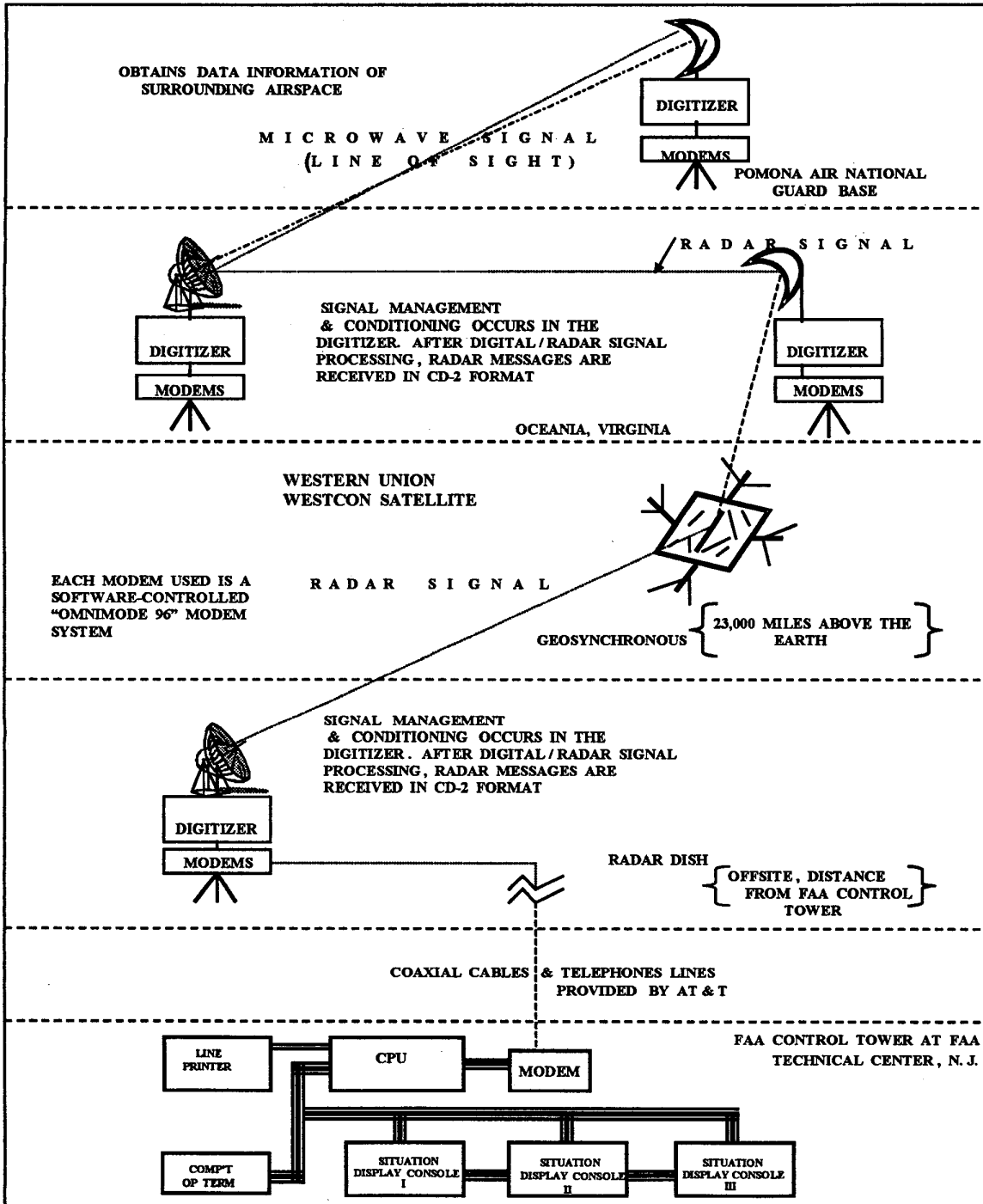

Figure 10. System Diagram of Proposed ASMS for the FAA Technical Center

## Conclusion

The preceding proposal defined a computer communications architecture for a radar system. This was an academic proposal created in the Spring of 1989. No real computer communications network for a radar system was composed by one person and purchased by the FAA Technical Center. However, the radar system and computer communications network design was based on real events in the procurement of a radar system. The entire computer and satellite communication network designs were based on open system approaches. This is because the software techniques and tools selected were designed to be versatile and compatible in the event of changes in the system.

Since this procurement occurred, radar surveillance and secondary surveillance technology has advanced. Some of these advances would date certain technical details discussed in this paper. Also, many radar systems currently in use throughout the country by the FAA still use the same operational technologies discussed in this paper. These radar systems include the Common Automated Radar Terminal System or Common (ARTS), the Airport Surveillance Radar 4 (ASR-4) and the Airport Surveillance Radar 8 (ASR-8). (The ASR-4 and ASR-8 would require a digitizer, while the ASR-9 and ASR-11 would not.)

As of this writing there are other systems undergoing operational test that the FAA has in the

terminal defined areas. Once all operational testing is deemed successful and these systems are fully deployed they will gradually replace some of the above mentioned systems already in use in the field.

## Acknowledgements

The author wishes to acknowledge the support received from members of the ACT and ATB test organizations. They represent the test community working on the latest radar / surveillance programs already in test and development at the Technical Center. They reviewed this paper and agreed there was no mention made of their programs.

## References

- [1] United Technologies Corporation, October 17, 1987, "Airspace Management System".
- [2] Racal-Milgo Information Systems, November, 1983, "Omni-mode 96, Preliminary Reference Manual".
- [3] Sanders-Defense and Information Systems Division, 1983 leaflet.
- [4] Stallings, William, 1985 "Data and Computer Communications", MacMillan Publishing Company, Chapters 2, 10, 11, 12 & 15.
- [5] Chen, C.H., 1992 "Computer Engineering Handbook", McGraw-Hill Series on Computer Engineering, Chapter 20.