

Propagation of Creeping Discharges in Air Depending on the Electric Field Direction and Insulator Materials under Lightning Impulse Voltage

M.A. Douar^{1,2}, A. Beroual¹ and X. Souche²

¹ Sicame S.A., LABEP, Avenue Basile Lachaud B.P. 1
19230 Arnac-Pompadour, France

² Ecole Centrale de Lyon, Laboratoire Ampère UMR CNRS 5005, 36 Avenue Guy de Collongue
69130 Ecully, France

Abstract – This paper is devoted to the influence of the direction of the applied electric field (namely perpendicular and parallel to the insulator surface) and the type of insulator materials on the propagation of creeping discharges (pattern and stopping length) in presence of air under standard lightning impulse voltage. The investigated materials belong to two distinguished families among the mostly used in electrical industry: (i) thermoplastics (namely polyamide 6 and polyarylamide), and (ii) one cycloaliphatic filled epoxy resin. It is shown that the stopping discharges length on a solid/air interface covers generally 55% of the creeping distance for both polarities under perpendicular E-field right before the flashover. While with parallel E-field, the stopping length is included between 20 to 30% for positive polarity and less than 25% for negative polarity. Also, the application of a perpendicular E-field is more straitened than the tangential one due mainly to the dielectric constant of polymers. Numerical simulations show that the electric field is more reduced for perpendicular E-field inferring that discharges (streamers) lengthen and develop easily at lower voltage levels.

Keywords— *creeping discharges; polymers; lightning; perpendicular field; parallel field.*

I. INTRODUCTION

The improvement of knowledge regarding the electrical and optical characteristics of creeping discharges is of a great interest for designing and sizing the insulation systems used in high voltage equipment. The surface discharges (commonly known as creeping discharges) are observed on the surface of some electrical components or on live line accessories (such as cable terminations, suspension insulators, bushings, solid insulations of power transformers, power capacitance or piercing connectors) when subjected to electric field particularly when the strength of this field exceeds a threshold value that is a major parameter. Actually, the creeping discharges are likely to take place on the surface of insulating structures after an excessive accumulation of space charges [1, 2] or when these structures are facing other constraints such as switching or lightning impulse waves [3-9]. The shape of these discharges is reminiscent of Lichtenberg figures and can be characterized by a fractal dimension that depends on both geometrical and physical factors [10]. Studies regarding discharges propagating over solid/air interfaces are less

numerous comparatively to those available on the pre-breakdown and breakdown phenomena in solids [11-13] or air alone [14].

From this perspective, the present paper deals with the analysis of the creeping discharges characteristics propagating over polymer surfaces (namely thermoplastics and one thermosetting filled cycloaliphatic epoxy resin) in presence of air at atmospheric pressure, under standard lightning impulse voltage for both polarities. The morphology of creeping discharges and their stopping lengths are investigated versus the polarity and magnitude of the applied voltage. Two electrode configurations simulating the effect of (i) perpendicular and (ii) parallel (tangential) electric fields to the insulator surface are considered.

II. EXPERIMENTS

The experimental setup is similar to that one used by our group in a previous work [6]. It consists of an optical system enabling to visualize the creeping discharges and a Marx generator (200kV – 2kJ) that provides positive and negative standard lightning impulse voltages (1.2/50 μ s). Two types of test cells containing two different electrode arrangements are used: (1) a needle – plane electrodes system with a needle perpendicular to the insulator to generate radial creeping discharges (Figure 1); and (2) a needle – bar electrodes system with a needle parallel to the insulator (Figure 2). The first test cell (perpendicular field) consists of a cylindrical core of 90 mm high and 110 mm inner diameter made of Teflon (PTFE); the upper cover was made of PMMA (transparent material) and the lower one that constitutes also the plane electrode, is of brass. The second test is also made of Teflon cell; it is of 112 mm inner diameter and 80 mm height. Its upper and lower covers were made of PMMA to permit the visualisation of creeping discharges on polymeric samples.

The needle electrode was of stainless steel and its radius of curvature, r_p , is of 11.4 μ m. This latter is checked under a microscope and changed each time an erosion is observed or the radius of curvature exceeds a critical value that is (15 μ m). The leakage distance between electrodes is taken equal to $d=43$ mm in the case of the perpendicular E-field while for the tangential E-field, the leakage distance is equal to 38mm, the point electrode being slightly inclined by an angle $\alpha=5.26^\circ$ toward the material surface.

The tested materials belong to two most known families: (i) thermoplastics (namely polyamide 6 (PA6/50) filled with 50wt% of glass fibers (GF) and polyarylamide (PARA/50) filled with 50wt% with GF); and (ii) one thermosetting cycloaliphatic epoxy resins filled with 66%wt of silica particles (FCEP). Polymeric samples inserted between electrodes are of square shapes with a side equal to 80mm and a thickness of 3mm. Table I shows materials properties provided by suppliers.

The optical observation of creeping discharges are based on embedding screen shots by using a CCD camera connected to a high performance data acquisition card (Meteor II/multichannel) driven by a software called MATROX Inspector 4.

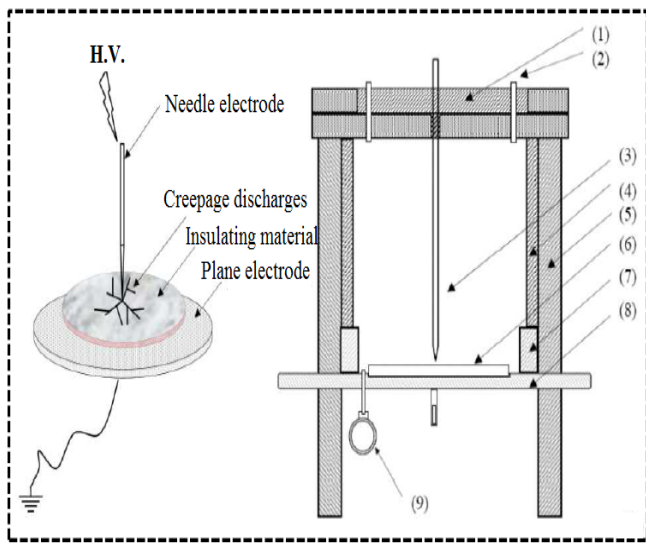

Fig. 1. Scheme of test cell used for the generation of radial creeping discharges: (1) Transparent lid, (2) Air Intake, (3) Needle electrode, (4) Cylindrical housing PTFE, (5) PVC rod, (6) Solid insulating sample, (7) Plexiglas, (8) Plane electrode, (9) Manometer.

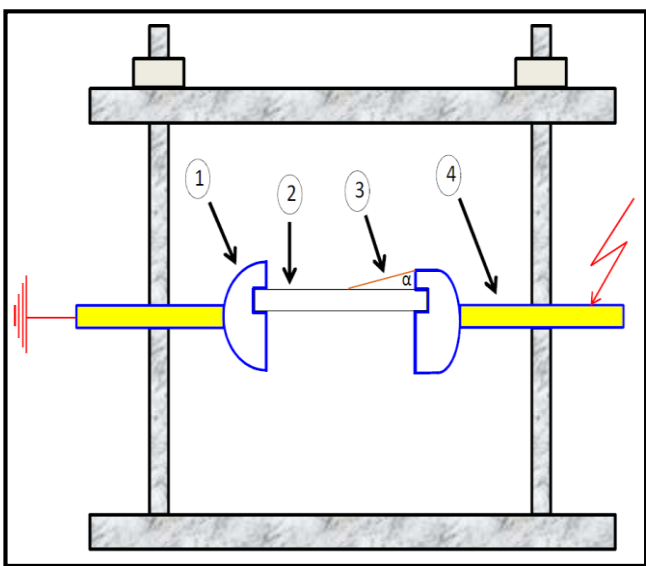

Fig. 2. Scheme of the test cell for the generation of tangential creeping discharges: (1) Electrode connected to the ground bar, (2) Polymeric sample, (3) H.V. needle electrode ($\alpha=5.26^\circ$), (4) H.V. bar source.

TABLE I. Properties of polymeric materials according to suppliers datasheets.

Properties (IEC or ISO)	PA6/50	PARA/50	FCEP
Tensile strength (MPa)	17500	20000	14500
Melting Temperature (°C)	222	280	350
Dielectric Strength (kV/mm)	40	31	29
Density (g/cm ³)	1.58	1.64	1.91
Resistivity (Ωm)	10 ¹²	10 ¹³	/
Dielectric constant (50Hz)	2.8	4.6	4

III. EXPERIMENTAL RESULTS AND DISCUSSION

A. Morphology of creeping discharges

1) *Perpendicular E-field*: The experimental setup for the generation of radial discharges is given in Figure 1. This arrangement simulates particular cases where the electric field is emphasized in some regions of insulating structures. Figures 3 and 4 depict some photos of discharges propagating on PA6/50 ($\epsilon_r=2.8$), PARA/50 ($\epsilon_r=4.6$) and FCEP ($\epsilon_r=4$) samples for positive and negative polarities.

We observe that the final length and brightness of creeping discharges increase with the applied voltage level as reported in [6,7]. The flashover voltage, V_{FOV} , of insulator samples depends also on the type of material; V_{FOV} is lower for PA6/50 than that for FCEP epoxy resin. Under positive polarity, the shape and the length of discharges depend on the material type, the polarity and the crest value of the voltage. For instance, the discharge is longer on polyamide 6 (PA6/50, Figure 3a) as the voltage level increases from 24kV to 27kV. Nevertheless, FCEP produces shorter discharges despite of higher voltage levels than those for PA6/50 between 30kV and 34kV (Figure 3b). When the point electrode is negative, the discharges inception voltage is higher than that with positive polarity for all samples; they are brighter and thicker (Figure 4). The comparison between PARA/50 (Figure 4a) and FCEP (Figure 4b) at 38kV shows that discharges on PARA/50 are the brightest but FCEP produces more discharges.

Actually, the flashover of insulating surfaces may result of the electronic emission mechanisms through space charges generation which depends in part on the type of material [15]. In this case, the generation of surface charges is an important factor which guides both the ignition and propagation of creeping discharges on polymeric surfaces [8]. This process is more active within PA6/50 explaining its lowest flashover value in comparison to FCEP. Grzybowski et al [16] also discussed the flashover mechanism in vacuum and concluded that the difference in FOV between materials may results of conditioning processes, the electron emission from the cathode region, charging of the insulator surface, desorption of surface gases and subsequent breakdown through these gases.

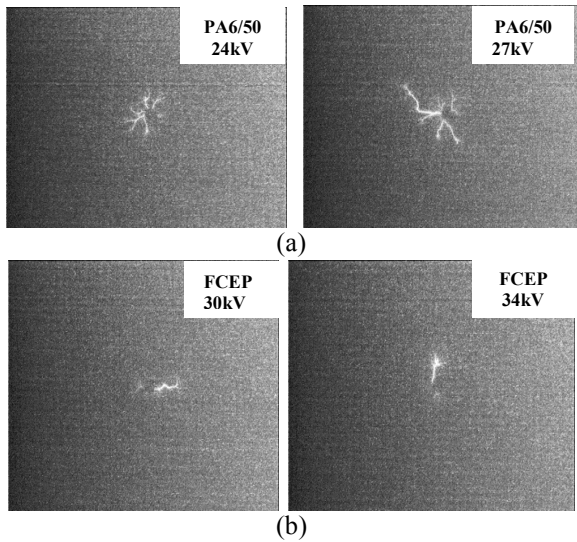

Fig. 3. Examples of discharges propagating over polymers for a positive needle in the case of perpendicular E-field: (a) PA6/50 and (b) FCEP.

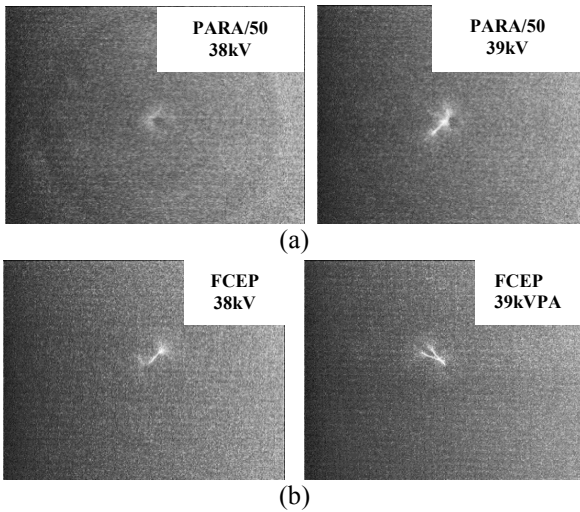

Fig. 4. Examples of discharges propagating over polymers for a negative needle in the case of perpendicular E-field: (a) PARA/50 and (b) FCEP.

2) *Parallel E-field*: Comparatively to perpendicular E-field for a positive needle electrode, the discharges originate from the HV needle electrode and propagate along the leakage distance of insulators (PA6/50 and FCEP) (Figure 5). One observes generally that only one discharge initiates and enlarges through polymeric surfaces tending to be thicker as the voltage level increases up to the flashover. When the needle is negative (Figure 6), the initiation of one creeping discharge is extremely difficult on PA6/50 even for higher voltage levels ($U > 45$ kV); that is also the case with the other investigated materials.

Regardless the field direction (perpendicular or parallel), the streamer development is easier with a positive needle than with a negative one while the intensity of the light emission is higher with a negative point especially for perpendicular E-field. One observes some noticeable differences between polymers subjected to a perpendicular E-field for both

polarities while this is not the case for parallel E-field.

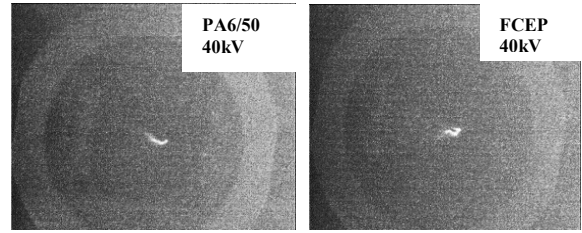

Fig. 5. Propagation of creeping discharges over PA6/50 and FCEP at 40kV for a positive needle and parallel E-field.

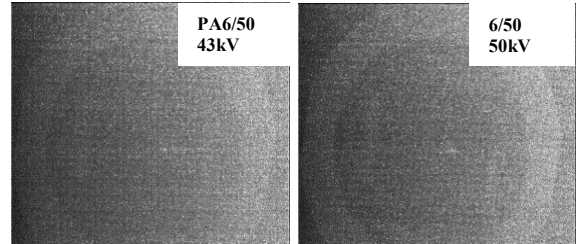
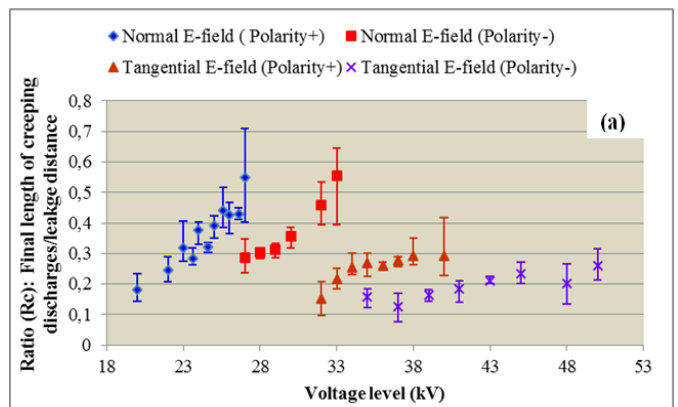

Fig. 6. Examples of discharges propagating over PA6/50 for a negative needle and parallel E-field.

B. Stopping length of creeping discharges

Figure 7 depicts the value of R_c right before the flashover regarding the type of a material, the direction of the electric field, the polarity and the voltage level. We observe that R_c increases with the voltage whatever the polymer (PA6/50, PARA/50 and FCEP). However, its value strongly depends on the type of material, the electric field direction and the voltage polarity. We note that the stopping length of creeping discharges is the longest when the electric field is perpendicular to the insulating surface for positive polarity (Figure 8a). As concerns the perpendicular E-field, R_c is generally included between 50 and 55% of the leakage distance for both polarities; the flashover needs higher voltage levels to occur when the point electrode is negative. For a parallel E-field (Figure 8b), R_c is included between 20 to 30% for PA6/50 and PARA/50 (Figures 7a and 7b) and between 35 to 40% for FCEP (Figure 7c) for the positive polarity. However, R_c does not exceed 25% for a negative polarity for all specimens.



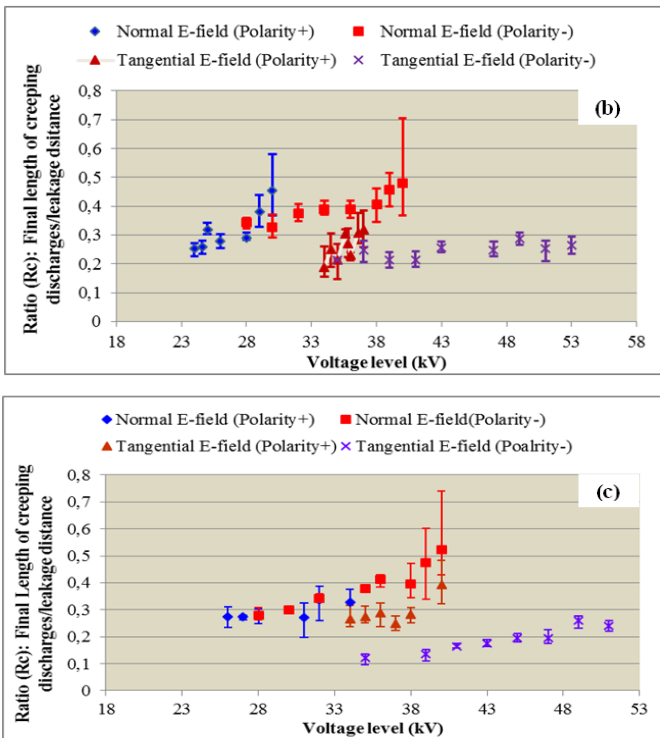

Fig. 7. Stopping ratio R_c of creeping discharges propagating over polymers versus the voltage for both polarities and E-fields: (a) PA6/50, (b) PARA/50 and (c) FCEP.

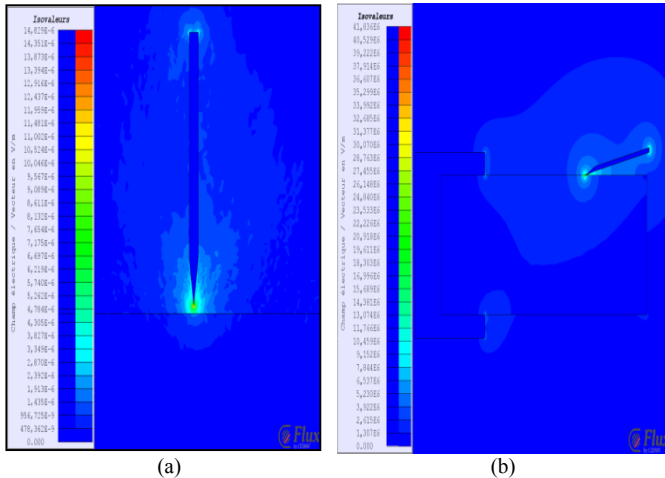

Fig. 8. Influence of the needle direction on the electric field intensity for PA6/50 ($\epsilon_r=2.8$) at 10kV: (a) perpendicular and (b) parallel E-fields.

IV. CONCLUSION

This work shows that the application of a perpendicular E-field is more straitened than the parallel one due mainly to the dielectric constant of polymeric material. For perpendicular E-field with a positive point, the creeping discharges are more branched for PA6/50 than for PARA/50 or FCEP, due to its lowest resistivity facilitating discharges to grow on its surface. For a negative polarity, the creeping discharges are less numerous with a shorter stopping length in comparison to the positive polarity. As concerns the parallel E-field, the growth

of discharges is considerably stopped under a negative polarity for all materials resulting of more reduced stopping length for both polarities oppositely to the perpendicular E-field.

It is also shown that the stopping discharges length on a solid/air interface covers generally 55% of the leakage distance for both polarities under perpendicular E-field right before the flashover. Regarding the parallel E-field, the stopping length is included between 20 to 30% for a positive polarity and less than 25% for a negative polarity.

REFERENCES

- [1] N.H. Ahmed, N.N. Srinivas, "Review of space charge measurements in dielectrics", IEEE Trans. Dielec. Electr. Insul., Vol. 4, No. 5, pp. 644-656, 1997.
- [2] T. Nitta and K. Nakanishi, "Charge accumulation on insulating spacer for HVDC GIS", IEEE Trans. Elect. Insul., Vol. 26, No. 3, pp. 418-427, 1991.
- [3] Y. Nakao, M. Naruse, H. Itoh, H. Suzuki, Y. Sakai and H. Tagashira, "Influence of a sort and thickness of solid insulators on the propagation of the positive creepage discharge in transformer oil", Trans. IEE Jpn., Vol. 116-4, No. 10, pp. 849-854, 1996.
- [4] R. Hanaoka, T. Kohrin, T. Miyagawa and T. Nishi, "Creepage discharge characteristics over solid-liquid interfaces with grounded side electrode", IEEE Trans. Dielec. Electr. Insul., Vol. 9, No. 2, pp. 308 - 315, 2002.
- [5] L. Kebbabi and A. Beroual, "Influence of the properties of materials and the hydrostatic pressure on creepage discharge characteristics over solid/liquid interfaces", IEEE Conf. Elect. Insul. Dielec. Phen. (CEIDP), Albuquerque, New Mexico, USA, 19-22, October 2003, pp. 293-296.
- [6] A. Beroual and L. Kebbabi, "Influence of the voltage waveform and hydrostatic pressure on morphology of final length of discharges propagating over solid/liquid interfaces", IEEE Trans. Dielec. Electr. Insul., Vol. 16, No. 6, pp. 1574-1581.
- [7] A. Beroual, M.L. Coulibaly, O. Aitken and A. Girodet, "Effect of micro-fillers in polytetrafluoroethylene insulators on the characteristics of surface discharges in presence of SF₆ CO₂ and SF₆-CO₂ mixtures", IET Gen. Trans. Distr., Vol. 6, No. 10, pp. 951 - 957, 2012.
- [8] H. Okubo, M. Kanegami, M. Hikita and Y. Kito, "Creepage discharge propagation in air and SF₆ gas influenced by surface charge on solid dielectrics", IEEE Trans. Dielec. Electr. Insul., Vol. 1, No. 2, pp. 294-304, Avril 1994.
- [9] P. Fracz, "Measurement of optical signals emitted by surface discharges on bushing and post insulator", IEEE Trans. Dielec. Electr. Insul., Vol. 20, No. 5, pp. 1909-1914, October 2013.
- [10] C. E. Magnusson, Lichtenberg figures, J. A.I.E.E. (American Institute of Electrical Engineering), Vol. 47, No. 11, pp. 828-835, November 1928.
- [11] P.P. Budenstein, "On the mechanism of dielectric breakdown of solids", IEEE Trans. Elect. Insul., Vol. 15, No. 3, pp. 225 - 240, 1980.
- [12] A.K. Jonscher, R. Lacoste, "On a Cumulative Model of Dielectric Breakdown in Solids", IEEE Trans. Dielec. Electr. Insul., Vol. 19, No. 6, pp. 567 - 577, 1984.
- [13] I.V. Lysitsin, H. Inoue, I. Nishizawa, S. Katsuki and H. Akiyama, "Breakdown and destruction of heterogeneous solid dielectrics by high voltage pulses", J. App. Phys., Vol. 84, No. 11, pp. 6262 - 6267, 1998.
- [14] P.N. Micropoulos, C.A. Stassinopoulos, B.C. Sarigiannidou, "Positive streamer propagation and breakdown in air: the influence of humidity", IEEE Trans. Dielec. Electr. Insul., Vol. 15, No. 2, pp. 416 - 425, 2008
- [15] N.C. Jaintly and T.S. Sudarshan, "In-situ insulator surface charge measurements in dielectric bridged vacuum gaps using an electrostatic probe", IEEE Trans. Dielec. Electr. Insul., Vol. 23, No. 2, pp. 261-273, 1988.
- [16] S. Grzybowski, J.E. Thompson and E. Kuffel, "Electric surface strength and surface deterioration of thermoplastics insulator in vacuum", IEEE Trans. on Elect. Insul., Vol. 18, No. 3, pp. 301-309, June 1983.