

Technology Development of Automated Rendezvous and Docking/Capture Sensors and Docking Mechanism for the Asteroid Redirect Crewed Mission

Heather Hinkel
 NASA – Johnson Space Center
 2101 NASA Road 1
 Houston, TX 77058
 281-483-1414
heather.hinkel-1@nasa.gov

Matthew Strube
 NASA – Goddard Space Flight
 Center
 Greenbelt, MD 20771
 301-286-7275
matthew.j.strube@nasa.gov

John J. Zipay
 NASA – Johnson Space Center
 281-483-8886
john.j.zipay@nasa.gov

Scott Cryan
 NASA – Johnson Space Center
 281-483-0466
scott.p.cryan@nasa.gov

Abstract—This paper will describe the technology development efforts NASA has underway for Automated Rendezvous and Docking/Capture (AR&D/C) sensors and a docking mechanism and the challenges involved. The paper will additionally address how these technologies will be extended to other missions requiring AR&D/C whether robotic or manned. NASA needs AR&D/C sensors for both the robotic and crewed segments of the Asteroid Redirect Mission (ARM). NASA recently conducted a commonality assessment of the concept of operations for the robotic Asteroid Redirect Vehicle (ARV) and the crewed mission segment using the Orion spacecraft. The commonality assessment also considered several future exploration and science missions requiring an AR&D/C capability. Missions considered were asteroid sample return, satellite servicing, and planetary entry, descent, and landing. This assessment determined that a common sensor suite consisting of one or more visible wavelength cameras, a three-dimensional LIDAR along with long-wavelength infrared cameras for robustness and situational awareness could be used on each mission to eliminate the cost of multiple sensor developments and qualifications. By choosing sensor parameters at build-time instead of at design-time and, without having to requalify flight hardware, a specific mission can design overlapping bearing, range, relative attitude, and position measurement availability to suit their mission requirements with minimal non-recurring engineering costs. The resulting common sensor specification provides the union of all performance requirements for each mission and represents an improvement over the current systems used for AR&D/C today. These sensor specifications are tightly coupled to the docking system capabilities and requirements for final docking conditions. The paper will describe NASA’s efforts to develop a standard docking system for use across NASA human spaceflight missions to multiple destinations. It will describe the current design status and the considerations and technologies involved in developing this docking mechanism.

TABLE OF CONTENTS

1. AR&D/C OVERVIEW	1
2. PREVIOUS AR&D/C MISSIONS AND HARDWARE USED	1

3. PROBLEMS ASSOCIATED WITH LEGACY APPROACH.....	4
4. AR&D/C COMMONALITY	5
5. CURRENT CAPTURE SYSTEM DEVELOPMENT ACTIVITIES.....	7
6. SUMMARY	7
REFERENCES.....	8
BIOGRAPHY	9

1. AUTOMATED RENDEZVOUS AND DOCKING/CAPTURE (AR&D/C) OVERVIEW

Automated spacecraft rendezvous and docking/capture is a vital component of advanced space operations. The ability for a spacecraft, with crew onboard or not, to autonomously rendezvous and capture/dock to another spacecraft fosters many benefits for deep space missions. This technology provides a substantial range of capabilities, from robotically re-servicing spacecraft to aggregating human spaceships before the crews even arrive — an efficient way to begin the long transit to the Mars system. NASA is driven to develop standards and identify commonality amongst programs to address these needs.

2. PREVIOUS AR&D/C MISSIONS AND HARDWARE USED

Sensors

There have been several on-orbit experiments and demonstrations for AR&D/C. These include NASA’s DART, JAXA’s ETS-VII and DARPA’s Orbital. The sensors flown in these demonstrations encompassed electromagnetic spectrum-based sensor technologies, ranging from radio frequency (RF) to visible and infrared wavelengths. Additionally, similar technologies have been used extensively in manned spaceflight rendezvous, proximity operations and docking (RPOD) at NASA.

RF sensors included radars, communication equipment and Global Positioning System (GPS) receivers. Radar systems, such as those flown on the Space Shuttle, relied on gimbaled antenna equipment and consumed a reasonable amount of power. The Ku-band radar on the Shuttle could track targets in low-Earth Orbit, but precluded operation of Ku-band communication with the ground. Communication equipment can be used to generate two-way ranging information, provided that the systems on both vehicles support the capability. The ISS provides means to generate range and range-rate measurements with incoming visiting vehicles once they are within space-to-space communications (typically within 30 km). The Progress, Soyuz, ATV, HTV, Dragon and Cygnus vehicles have all demonstrated RF communication-based ranging capabilities. GPS receivers have been used to provide absolute GPS state differencing (Delta-AGPS), or the processing of raw measurements for relative GPS (RGPS) positioning. Delta-AGPS and RGPS have been demonstrated on ISS visiting vehicles such as ATV, HTV, Dragon and Cygnus. These approaches rely on either complex systems or coordination between the two spacecraft. Radar can support non-cooperative targets, but requires a powerful and complex antenna system that is able to detect and track a spacecraft. Communication-based ranging requires both vehicles have the ability to receive, process and return messages to the other craft. Delta-AGPS and RGPS requires communication and sharing of data for prompt processing, in addition to being suitable for Earth-orbiting spacecraft.

Visible and infrared wavelength electromagnetic (EM) spectrum-based sensors include visible camera, infrared (IR) cameras and light, detection and ranging (LIDAR) systems. Visible cameras offer the ability to passively detect spacecraft, but require proper lighting conditions. IR cameras operating in the near and short wavelength IR bands enable detection and tracking of spacecraft without the need of specific lighting conditions. Boeing's Orbital Express was a platform for demonstrating visible camera and IR camera processing during AR&D. SpaceX's Dragon utilizes IR camera and image processing to provide the relative navigation filter range data. LIDARs, scanning or flash, operate independently of the lighting conditions, but require that the sensor illuminate the target vehicle with an EM source, such as SWIR lasers. The advantage of EM-based sensors is their ability to operate with less power consumption, greater range, operational flexibility and decreased infrastructure when compared to the RF-based sensors. Additionally, visible and IR cameras are passive systems and do not need to "ping" the target vehicle to compute measurements, but rely on environmental factors such as lighting and thermal signatures. The Space Shuttle employed a scanning LIDAR that provided range and bearing data to the crew during rendezvous and docking with the Mir and the ISS. Many of the ISS visiting vehicles (ATV, HTV, Dragon and Cygnus) employ various LIDARs for primary sensing during RPOD activities. These LIDARs are either scanning or flash-based. Additionally, Dragon utilizes IR cameras to augment the LIDARs during long-

range RPOD, and are used for FDIR cross-checks. The use of LIDARs and IR cameras has shown excellent performance. The Space Shuttle acted as a testbed for three (3) LIDARs on several missions. These experiments provided a platform for each supplier to test and refine their sensor technology, further enhancing them to meet the prospective needs of future vehicles.

Capture Systems

Capture systems between two spacecraft have evolved over time. The Probe and Cone systems used on the NASA Apollo vehicles (see Figure 1) and still in use today on the Russian Soyuz and Progress vehicles (Figure 2) require relatively high contact velocities to achieve capture. They are lighter in weight to the Androgynous Peripheral Docking System (APDS), Figure 3, and the NASA Docking System (NDS), Figure 4, which are "peripheral" capture systems in that the soft capture latches reside around the circumference, or periphery, of the mating interface. An early version of the APDS was used during the Apollo-Soyuz Test Project and this mechanism was later evolved to make Shuttle Orbiter Dockings with the Mir Space Station possible. A further evolution resulted in the APDS being attached to Pressurized Mating Adapters -1, -2 and -3 and launched to the International Space Station (ISS). PMA-1 and PMA-2 were part of the initial deployment of Unity (Node-1) in 1998 on STS-88. The APDS on the ISS was the mechanism used by the Space Shuttle Orbiter to dock with the ISS via the PMAs.

The advantage of a peripheral attach system is that lower contact forces can achieve soft capture, at the expense of added complexity and mechanism weight. Both types of capture systems, central and peripheral; have been used reliably for human spacecraft systems throughout the decades. The choice of which system to use depends on the mission requirements.

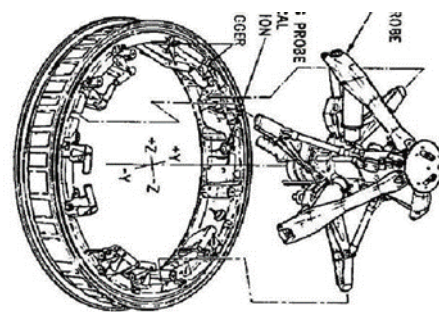

Figure 1 - Apollo Probe and Cone

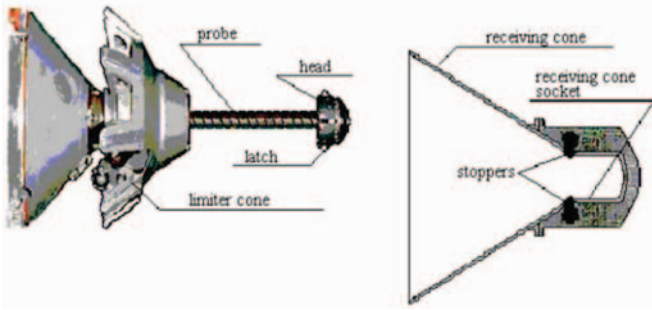

Figure 2 - Soyuz Probe and Cone



Figure 3 - Orbiter APDS



Figure 4 - NASA Docking System

Cooperative Targets

Targets on cooperative vehicles can be passive or active. Most of the manned spaceflight targets have been visually-based; therefore, passive. Docking targets used on Mir and ISS have evolved their target patterns to aid the crew with piloting the vehicles in their docking corridors. The target features include angular markings so that the crew can determine their position and angular offsets. The targets have undergone design changes based on docking mechanisms and sensor technology advancement.

Target placement is dictated by sensor location and available locations on the target vehicle. These can be

outside the docking mechanism, or inside the docking mechanism vestibule, if possible. The Russian space station Mir was a testing ground for multiple target patterns and designs (see Figure 5), providing the early foundation for the International Space Station targets (see Figure 6).

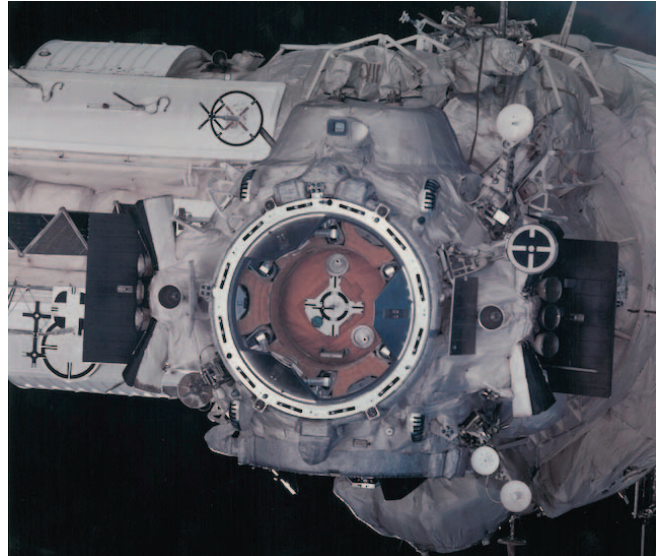

Figure 5 - Mir APAS docking mechanism (image STS-071-701-063)

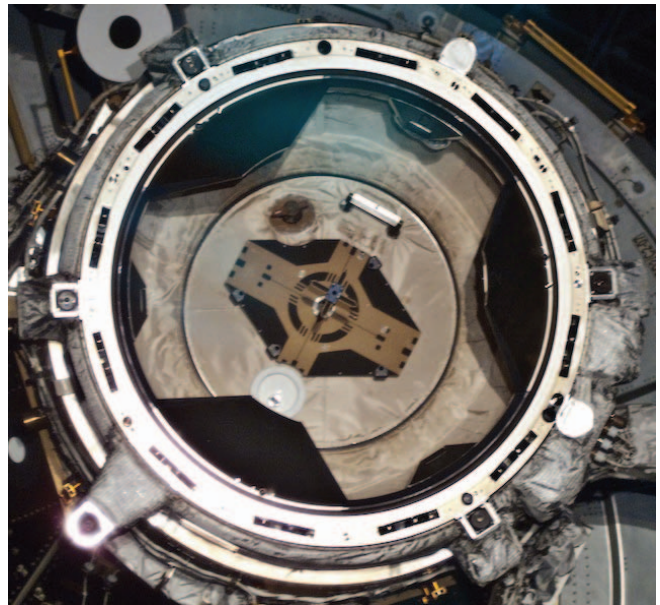

Figure 6 - ISS PMA2 docking mechanism (image s132e007927)

Sensor requirements can also impact the target design. STS-134 DTO required that the ISS PMA2 visual docking target be augmented with reflective elements in an asymmetric pattern to enable precise relative position and relative attitude determination. Additionally, the augmented target provided the capability of ISS to support future manned and unmanned spacecraft docking using LIDAR-based sensors, such as Orion's Vision Navigation Sensor (VNS). Closer inspection of Figure 6 - ISS PMA2 docking mechanism

(shows that the visual docking target has five (5) small purple-colored reflective elements. The purple portion is anodized titanium, and contains a 10 mm diameter reflective material disc in the center of each reflective element.

In addition to visual targets, retroreflector corner cube assemblies have been placed at strategic locations on the ISS. A single planar corner cube is mounted to the front of PMA2 (bottom left corner in Figure 6). The corner cube provides long-range detection and tracking with LIDARs, while the reflective elements on the PMA visual target provide short-range tracking in support of proximity operations and docking.

Use of docking targets and corner cubes at known locations on a target vehicle enable rapid processing provided that the chasing spacecraft has knowledge of those assets. These features offset the need for target vehicle modeling for feature tracking algorithms. The other approach, termed non-cooperative, does not employ any unique targets or assets on the target vehicle. Active and passive sensors can use target vehicle knowledge in the form of CAD models or unique shape/features, provided that the target vehicle information is contained in the chaser vehicle's algorithms. Algorithms such as natural feature image recognition (NFIR) rely on vehicle models to determine the target vehicle's relative state with respect to the chaser vehicle.

3. PROBLEMS ASSOCIATED WITH LEGACY APPROACH

These highly successful missions and demonstrations have provided different government agencies and commercial companies extensive experience in designing, building, testing, and operating RPOD systems, particularly in component systems such as sensors. Given the novelty of relative navigation in the space environment, there weren't many flight-qualified hardware options in the form of off-the-shelf (OTS) systems. The lack of ready-made options led engineers to design their own hardware solutions, or modify systems used in the national defense arena. These modifications or developments resulted in hardware designed and qualified to the exact mission requirements and environments. While these hardware solutions worked extremely well for these early missions, the designs were typically one-offs and their extensibility to future missions was very limited. Even hardware designs for the sensing and docking strategies between concurrent missions differed greatly.

As a result, engineers today are still dealing with the lack of OTS options for sensing and capture hardware and are required to spend significant amounts of time and money engaging in non-recurring engineering efforts. Heritage development does provide a much-needed starting point on hardware design and typically, at first glance, the old hardware design seems "tunable" to the new mission concept—change a wavelength here, adjust the field of view

there. As the engineering team initiates the detailed design phase, however, they typically rediscover the interdependence of the design choices made in legacy hardware and experience a ripple effect of changes required to adapt legacy hardware to new mission designs. Typically, project managers are the ones that desire a direct link to previous missions, and to claim the "re-use" of heritage components, in order to show design maturity and present a reduced technical, schedule, and cost risk posture. When done early in the mission—during the proposal or project formulation phase—when discipline engineering support is typically light, these "claims" of heritage can be asserted without much supporting details. The trouble is that this is also the timeframe when project and subsystem budgets are set—the disconnect between assumptions in hardware reuse and reality can lead to significant cost growth and schedule delays if not caught early.

These cost and schedule issues are only exacerbated by the typical multi-year delays between missions requiring RPOD systems. These gaps between missions introduce a host of re-build risks that drive system development such as parts obsolescence and lost talent and vendors. Parts obsolescence is a major contributor to the inability to reuse a piece of hardware, or even significant portions of the original design. The continued advancement of parts and components, in particular EEE parts, can also entice designers to add capability to the unit, with no added increase in size, weight, and power, which further leads to additional non-recurring engineering costs. Those designers of the original unit may also no longer be with the developing company or agency in which case engineers won't have access to previous design decisions and undocumented trade studies in order to assess the applicability of new design changes.

In the end, all of these issues combine in a positive feedback loop that usually results in significant amounts of engineering effort to adapt fragile heritage hardware systems to new missions. This scenario is unsustainable. When the lack of other government or commercial interests—whether in the form of dedicated RPOD missions and demonstrations or in the form of collaborations—leads to a single entity—like NASA—providing a significant majority of the resources required, this unsustainable situation becomes an even larger burden.

And now we are doing something about it! Over the last five years, NASA has been working internally, through different working groups and an Agency-wide AR&D Community of Practice, which is supported through the NASA Engineering and Safety Center (NESC), to work together across the Centers to pool our resources and develop systems and architectures that not only meet the needs of today but are designed upfront to be tunable, adjustable, and flexible to support multiple projects and future mission concepts. When these plans are combined with the desire to extend RPOD hardware to the world of non-cooperative rendezvous—to legacy satellites not designed for docking or to the surface of interplanetary

bodies—NASA is working towards developing common suite of sensing and capture systems that will enable the RPOD missions of the future, such as the Asteroid Redirect Mission (ARM).

4. AR&D COMMONALITY

During preparation for the Asteroid Redirect Mission it became apparent that it was prudent to look for commonality amongst the two robotic-vehicle concepts and the crewed-vehicle concept. NASA Associate Administrator Bill Gerstenmaier assembled a group of AR&D experts from five NASA field centers and the NASA Engineering and Safety Center (NESC) to determine if such commonality existed. First, the team looked at what sensors (each of which had their own development effort) were currently planned for each mission. Common across the three missions were one or more visible cameras, a 3D LIDAR and consideration/inclusion of an infrared camera for situational awareness/robustness. See *Figure 7* for details.

	Far Field	Near Field	Final Approach	Mate
	Rendezvous	Proximity Operations	Final Approach/Alignment	Docking/Capture
Common across missions	Narrow Angle Camera - visible Camera - infrared	Medium Angle Camera - visible Camera - infrared LIDAR	Wide Angle Camera - visible Camera - infrared LIDAR	Wide Angle Camera - visible Camera - infrared
Sensors unique to only some of the missions were excluded from the common suite	RF comm Star tracker LIDAR/laser range finder	RF comm Ground penetrating radar		LIDAR

*Infrared cameras included for robustness/situational awareness

Figure 7 - AR&D Concepts of Operations Overview

It was immediately clear that sufficient commonality existed to warrant a deeper look. NASA is developing two robotic mission concepts for the ARM, to be down-selected at a future point. One concept uses a robotic spacecraft to capture a whole small near-Earth asteroid and another uses largely the same robotic spacecraft to capture a cohesive mass from the surface of a larger asteroid. In both mission concepts, the asteroid mass would be redirected into a stable orbit around the Moon. Astronauts aboard the Orion spacecraft launched on the Space Launch System (SLS) would rendezvous with the vehicle containing the captured asteroid mass in lunar orbit and collect samples for return to Earth. The AR&D mission concepts of operations for types of sensors used and the way in which those sensors were used were documented in great detail. A summary of that study can be found in *Figure 8*.



	Long Range	Medium Range	Close Range
Crewed Asteroid Mission 	S-Band Transponder for Range/Range Rate to reduce timeline; Star Tracker for bearing High Resolution Camera for bearing		3D LIDAR for precise alignment for docking High Resolution Camera for secondary pose
Small Asteroid Capture 		Medium Resolution Camera for asteroid acquisition, spin rate and bearing to the asteroid	3D LIDAR for asteroid characterization and alignment for bag capture
Robotic Boulder Capture 	Medium Resolution Camera for bearing to the asteroid	Medium and High Resolution Cameras for spin rate, 3D map of the surface and boulder identification	3D LIDAR for 3D range images to the target boulder Medium and High Resolution Cameras for spacecraft pose and images of boulder collection areas

Figure 8 - ARM AR&D Concepts of Operations Overview

Other future NASA AR&D missions were also considered, for example satellite servicing, lunar/planetary rendezvous and docking as well as autonomous landing and hazard avoidance.

A selection of these sensors could be used on each mission to eliminate the cost of multiple sensor developments and qualifications. By choosing sensor parameters at build-time instead of at design-time and, without having to re-qualify flight hardware, a specific mission can design overlapping bearing, range, relative attitude, and position measurement availability to suit their mission requirements with minimal non-recurring engineering costs.

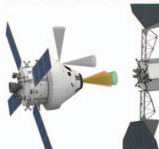
NASA identified the driving attributes of each of the asteroid missions as well as the other future NASA AR&D missions mentioned to develop the beginnings of a specification. The resulting common sensor specification provides the union of all performance requirements for each mission and represents an improvement over the current systems used for AR&D today. The common specification

identified a set of environmental requirements common to each concept of operation. These values are shown below in Table 1. Where possible, it was noted where an attribute could be instantiated in a modular fashion, or where the sensor design includes build-time options that can change its intended use. One example is target albedo: a sensor built for the ARV could be assembled differently than one assembled for Orion in order to meet the low albedo of the asteroid as opposed to the potentially highly-reflective target on the ARV. While such modularity works for the asteroid applications covered here, extension to other future missions such as satellite servicing may require both ends of the attribute spectrum. The top-level performance attributes required to meet all three of the mission concept of operations, for each type of sensor, is given in

Table 2. The intent of the common specification is to meet all of the driving AR&D requirements for each mission, including Orion.

Table 1 - Environmental Commonality Specification

Attribute	Units	Specification	Notes
Operational Regime	NA	Deep space and cis-lunar	
Mission Duration	Years	> 7	
Sensor On-time	Hours	> 1600 (not for all sensors in the suite)	The suite is used as described in the supporting materials on the BAA website. Accounting for duty cycling, the on-time could be shorter.
Operational Thermal Range	deg C	-30 to +50	Survival temperature range should be wider than the operational.
Tested Partial Pressure	Pa	< 1e-5	The actual environment will be a hard vacuum.
Total Ionizing Dose (*)	kRad Si	> 100	Computed TID should account for sensor on-time and mission elapsed time, which are different from each other
Single Event Upset Rate	Upsets/day	< 1e-2	Computed rates should be for functional upsets only that require a power cycle or configuration reload from stored memory.
Asteroid Size	Meters	2-500	Small sizes apply to reference mission and larger sizes apply to alternate
Asteroid visible albedo (*)	%	> 3	Depends on material make up with 3% being a minimum
Docking target reflectance (*)	%	> 90	Docking target to use retro-reflectors
Sun Exposure Survival	Hours	Indefinite	No requirement to operate with Sun in view

Table 2 - Commonality Specification for each Sensor Type

	Visible Camera	Infrared Camera	LIDAR
Minimum Operational Range	1 m	1-2 m	1 m
Maximum Operational Range	> 1000 km (bearing only)	10 to 20 km (bearing only)	> 2 km (range and bearing)
Operational Field of View	Selectable, 10° to 60°	Selectable, 10° to 60°	±10°
Detector Array Size	≥ 1024x1024 pixels	≥ 1024x1204 pixels	≥ 256x256 pixels
Range Accuracy	NA	NA	Precision: 2 cm (1- sigma) within a frame Accuracy: 2 cm (1-sigma) at 2 m separation
Wavelengths (*)	400 – 700 nm	8 – 12 um	ARV: no restrictions Orion: Eye safe
Depth of Focus (DoF)	< 1m min > 1000m max	< 1m min > 1000m max	< 1 m min > 100m max
Contrast over DoF	10% at pixel sampling rate	10% at pixel sampling rate	10% at pixel sampling rate
Focus at Infinity	COC ≤ 2 x Airy central lobe	N/A	N/A
Max Response	80%	80%	80%
Min Response (SNR)	≥ 10	≥ 10	≥ 10
Frame Rates	5 – 10 Hz	3 – 5 Hz	5 – 10 Hz
Dynamic Range	> 1000:1	> 1000:1	NA

NASA acknowledges that as technology improves, changes, and matures, the common sensor suite will need to change and adapt. NASA invites innovative ideas for how to incrementally improve this sensor suite as technology improves and advances. Examples include advances in the regime of noise radar, computing, and other technologies that could enable new approaches to AR&D. New technologies could result in savings on size, weight, power, and complexity. NASA would like to establish incremental growth in AR&D/C capability including the ability to operate in parallel to other solutions to demonstrate the technology prior to integrating it into the primary solution set.

NASA completed two Phase I Broad Agency Announcement (BAA) contracts to validate the common spec, address what modifications would need to be made to their sensor to meet this spec and risk reduction activities to achieve these modifications.

5. CURRENT CAPTURE SYSTEM DEVELOPMENT ACTIVITIES.

NASA is currently developing an International Docking Adapter (IDA), which will be placed on the International Space Station (ISS) to provide an interface with any spacecraft with an International Docking System Standard (IDSS)-compliant mechanism. The IDSS is being negotiated between NASA, ESA, JAXA and Roscosmos to provide a generic interface for spacecraft to dock with one another.

Since the ISS used the Androgynous Peripheral Docking System (APDS) attached to the Pressurized Mating Adapters (PMAs) for Space Shuttle Orbiter dockings, a new pressurized tunnel called the IDA, with an APDS on one end and an IDSS-compliant docking mechanism on the other end must be sent to the ISS so that commercial and international vehicles that follow the IDSS can dock to it. A depiction of the IDA is provided in Figure 9.

Two IDAs will be flown to the ISS in the trunk of the SpaceX Dragon cargo vehicle. Each IDA will be extracted by the Space Station Remote Manipulator System (SSRMS) and mated to PMA-2 and PMA-3. This will provide redundant capability for docking to the ISS.

NASA, through a contract with The Boeing Company, is building the NASA Docking System, which will be IDSS-compliant and attached to the IDA to act as the docking interface for the crewed vehicles built under the Commercial Crew Transportation Capabilities (CCtCap) Contract. It is expected that vehicles built for the CCtCap will use an IDSS-compliant docking mechanism to mate to the ISS.

One of the features of the NASA Docking System that makes it unique is the ability to capture an oncoming vehicle at much lower force levels than previous docking mechanisms. Previous docking mechanism designs, including the APDS and Probe and Cone-type mechanisms require greater initial velocities to achieve soft capture. This has the effect of imparting large dynamic loads into the structure. These loads size the interface structure and appendages such as solar arrays or radiators. A docking mechanism that does not require large forces to achieve soft capture can reduce the structural weight of the entire spacecraft. Since future missions beyond Low Earth Orbit will be severely mass constrained, advances in mating system technology can provide benefits across the entire spacecraft system.

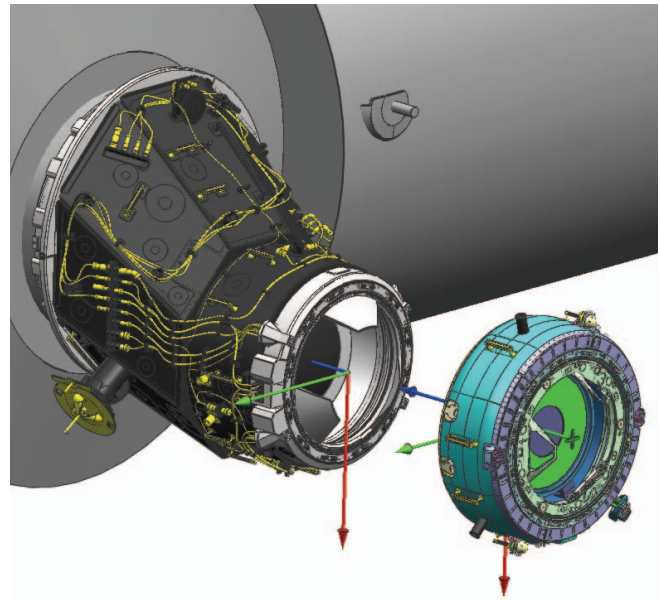

Figure 9 - IDA to PMA interface

6. SUMMARY

As described, automated spacecraft rendezvous and docking/capture is a vital component of advanced space operations. These technologies provide a substantial range of capabilities. NASA is working to develop standards and identify commonality amongst programs to address these needs.

REFERENCES

- [1] NESC Review of Demonstration of Autonomous Rendezvous Technology (DART) Mission Mishap Investigation Board (MIB) Review, NESC RP-06-119, December 2006.
- [2] A Summary of the Rendezvous, Proximity Operations, Docking and Undocking (RPODU) Lessons Learned from the Defense Advanced Research Project Agency (DARPA) Orbital Express (OE) Demonstration System Mission, C.J. Dennehy & J.R. Carpenter, NESC-RP-10-00628, April 2011.
- [3] Relative Navigation Light Detection and Ranging (LIDAR) Sensor Development Test Objective (DTO) Performance Verification, C.J. Dennehy, NESC-RP-11-00753, May 2013.
- [4] Space Shuttle Relative Navigation Papers, Volumes 1 & 2, Compiled by J. Goodman/USA, JSC-35054, July 2011.
- [5] Asteroid Initiative BAA.

BIOGRAPHY

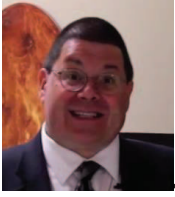

John J. Zipay received a B.S. in Aerospace Engineering from Polytechnic University in 1988. He received his Master's Degree in Mechanical Engineering from the University of Houston in 1999. He has been with the NASA – Lyndon B. Johnson Space Center for over 30 years. He has been the Structures Integration Manager for the International Space Station Program and is now the Deputy Branch Chief of the Structures Branch at JSC. He has participated in the Shuttle Orbiter TPS Tile Repair effort supporting Return to Flight after the Columbia Accident, is a member of the AIAA Structures Technical Committee, an Associate Fellow of the AIAA and has participated in many flight hardware development projects throughout his career.



Heather Hinkel is the Agency Lead for Automated Rendezvous and Docking (AR&D). In that capacity she is leading a multi-center NASA team for common AR&D sensors amongst other responsibilities. Ms. Hinkel served as the principal investigator for the successful Orion Sensor Test for Orion Relative-Navigation Risk Mitigation (STORRM). Ms. Hinkel has spent her career at NASA Johnson Space Center, concentrating on the rendezvous and proximity operations flight phases, specifically on-orbit relative navigation. Throughout her career she has served in key roles for several Shuttle flight tests and was a key developer and project manager of the Rendezvous and Proximity Operations Program (RPOP) which was used on every Shuttle rendezvous mission starting with STS-51. Ms. Hinkel received a B.S. in Aerospace Engineering and Mechanics from the University of Minnesota.



Matt Strube served as the Rendezvous and Proximity Operations (RPO) Manager for the Satellite Servicing Capabilities Office at the Goddard Space Flight Center. Since joining the Agency in 2005, Mr. Strube has spent his energy in advancing component hardware technologies, most recently focusing on advancing RPO sensor applicability to the wide range of RPO missions being proposed by NASA and other Government agencies. Mr. Strube also served as the project manager for Raven, an autonomous relative navigation demonstration to the International Space Station, which is scheduled to launch in 2016. Mr. Strube received a B.S. and Master's Degree in Aerospace Engineering from the University of Maryland at College Park.



Scott Cryan received a BS in Aerospace Engineering from SUNY Buffalo in 1988. He has worked for various contractors at NASA-JSC since 1988, through 2004. In 2004, Mr. Cryan took a position at NASA-JSC, and has served as the Orion Relative Navigation Hardware Subsystem Manager. Currently, Mr. Cryan is the ISS Rendezvous, Proximity Operations and Capture/Docking lead for JAXA's HTV and Boeing's CST-100, overseeing all issues relating to ISS safety pertaining to the visiting vehicles during the RPOC/D regime. Mr. Cryan has been working with navigation hardware throughout his career, including data analysis, math model development/integration, and sensor requirements, testing and integration.