

Miniaturized Wilkinson Power Dividers Utilizing Capacitive Loading

Maximilian C. Scardelletti, George E. Ponchak, and Thomas M. Weller

Abstract—This letter reports the miniaturization of a planar Wilkinson power divider by capacitive loading of the quarter wave transmission lines employed in conventional Wilkinson power dividers. Reduction of the transmission line segments from $\lambda/4$ to between $\lambda/5$ and $\lambda/12$ are reported here. The input and output lines at the three ports and the lines comprising the divider itself are coplanar waveguide (CPW) and asymmetric coplanar stripline (ACPS), respectively. The 10 GHz power dividers are fabricated on high resistivity silicon (HRS) and alumina wafers. These miniaturized dividers are 74% smaller than conventional Wilkinson power dividers, and have a return loss better than +30 dB and an insertion loss less than 0.55 dB. Design equations and a discussion about the effect of parasitic reactance on the isolation are presented for the first time.

Index Terms—Coplanar stripline, coplanar waveguide, power dividers, Wilkinson power dividers.

I. INTRODUCTION

WILKINSON power dividers [1] are indispensable components of microwave amplifier and antenna distribution circuits, however conventional power dividers are quite large, especially below X-Band where the quarter-wave transmission lines can be several millimeters long. Consequently, when they are incorporated into monolithic microwave integrated circuits (MMICs), the circuit's size depends heavily on the size of the power dividers. Therefore, techniques to reduce the size of power dividers are required for low cost and small size circuits. One of the first methods to reduce circuit size used capacitive loading to miniaturize hybrid couplers [2]. Small, lumped element Wilkinson power dividers have recently been reported [3], but these designs are very dependent on the quality factor and self-resonant frequency of the inductors. Other approaches to reduce the size of Wilkinson power dividers include the use of stepped impedances [4], large inductance through the application of transverse slits [5], and capacitive loading [6], [7].

In this paper, the quarter-wave transmission lines of a Wilkinson power divider are reduced using capacitive loading and the transmission line characteristic impedance is correspondingly increased. To fully illustrate this approach, the characteristics of Wilkinson power dividers with transmission line lengths from $\lambda/5$ to $\lambda/12$ are presented and compared to the conventional, $\lambda/4$ Wilkinson power divider and a lumped

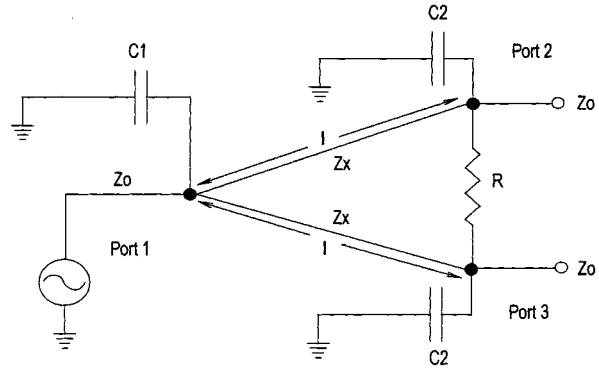

Fig. 1. Schematic of miniaturized Wilkinson power divider.

element Wilkinson power divider. The circuits use planar transmission lines, CPW and ACPS, because they are easy to fabricate. The comparison includes the measured insertion loss, 15 dB return loss bandwidth, and the circuit size. Furthermore, the first discussion about the shift in the isolation observed in reported results and the low pass filter characteristics of miniaturized Wilkinson power dividers is presented.

II. MINIATURIZED WILKINSON POWER DIVIDER ANALYSIS

The schematic of the capacitively loaded Wilkinson power divider is shown in Fig. 1. To analyze the circuit and determine the values of the transmission line impedance (Z_X), the capacitors (C_1 and C_2), and the resistance (R) for a given transmission line length (l), an *even-odd mode analysis* was performed [8]. For zero reflection from all three ports and infinite isolation between ports 2 and 3, it is found that C_2 must equal $2C_1$ and $R = 2Z_0$. Furthermore, Z_X and C_1 for any desired transmission line length (l) are

$$Z_X = \frac{\sqrt{2}Z_0}{\sin(\beta_0 l)} \quad (1)$$

$$C_1 = \frac{\cos(\beta_0 l)}{\omega_0 \sqrt{2}} \quad (2)$$

where Z_0 is the characteristic impedance of the system, β_0 is the propagation constant at the design frequency, and ω_0 is the angular frequency at the design frequency. Values of C_1 and Z_X as a function of the transmission line length l are listed in Table I. Also shown in Table I is the percent reduction in transmission line length and circuit area compared to the conventional, $\lambda/4$ Wilkinson power divider.

Manuscript received July 3, 2001; revised October 19, 2001. The review of this letter was arranged by Associate Editor Dr. Arvind Sharma.

The authors are with NASA Glenn Research Center at Lewis Field, Cleveland, OH 44135 USA.

Publisher Item Identifier S 1531-1309(02)00862-0.

TABLE I
CAPACITOR AND TRANSMISSION LINE LENGTHS OF MINIATURIZED WILKINSON POWER DIVIDERS

Electrical Length (l)	Capacitance (C_l : pF)	Characteristic Impedance (Z_c : Ω)	ACPS Line Length (l) (μm)	Percent reduction in l from $\lambda/4$	Area of Device (mm^2)	Percent reduction in area from $\lambda/4$
$\lambda/4$	0	70.7	2974	0	3.2	0
$\lambda/5$	0.07	74.4	2381	19.93	2.5	19.9
$\lambda/6$	0.113	81.7	1984	33.28	1.8	43.3
$\lambda/7$	0.14	90.4	1701	42.8	1.5	51.4
$\lambda/8$	0.16	100	1488	49.96	1.3	57.5
$\lambda/9$	0.17	110	1323	55.51	1.1	65.5
$\lambda/10$	0.18	120.3	1191	59.95	0.98	69.0
$\lambda/11$	0.19	130.8	1082	63.61	0.89	71.8
$\lambda/12$	0.195	141.4	992	66.64	0.82	74.2

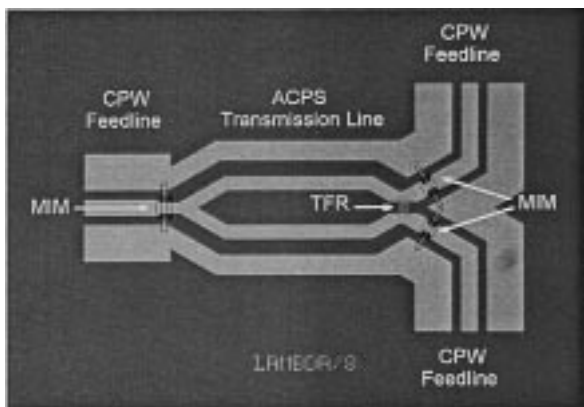

Fig. 2. Photograph of miniaturized Wilkinson power divider fabricated on high resistivity Si with $l = \lambda/8$.

III. CIRCUIT FABRICATION AND MEASUREMENTS

The circuits were fabricated on high resistivity silicon (HRS) ($\rho > 2500 \Omega\text{cm}$) and alumina substrates with dielectric constants of 11.7 and 9.9 and substrate thicknesses of 400 and 500 μm , respectively. Standard IC processing that includes four deposition steps consisting of Cr/Au/Cr (200/11 000/200 \AA) for the metal-insulator-metal (MIM) capacitor lower electrode metal, SiO_2 (4900 \AA) for the MIM capacitor dielectric layer, Ti (175 \AA) for the thin-film resistor (TFR), and Cr/Au (200/12 500 \AA) for the transmission lines. A circuit fabricated on HRS with a transmission line length of $\lambda/8$ is shown in Fig. 2.

The power dividers were characterized on an HP 8510 vector network analyzer (VNA) and an RF probe station. A thru-reflect-line (TRL) calibration implemented through the program Multical was performed using calibration standards fabricated on the substrate with the circuits [9]. To cover the frequency band of 0.45 MHz to 50 GHz, 7 delay lines were used of lengths 650, 844, 1055, 1849, 2950, 6000, 15 000 μm . Since the Wilkinson power divider is a three port circuit and the VNA is a two port system, the third port of the circuit was terminated with a specially built Picoprobe (GGB Industries) that incorporates a 50 Ω termination.

IV. RESULTS AND DISCUSSIONS

The measured insertion loss of the 10 GHz, miniaturized power dividers fabricated on HRS and alumina is displayed as a function of transmission line length in Fig. 3. The dividers exhibit an insertion loss not greater than 0.55 dB for line lengths from $\lambda/5$ to $\lambda/12$. Also shown in Fig. 3 is the measured insertion loss for a lumped element Wilkinson power divider from

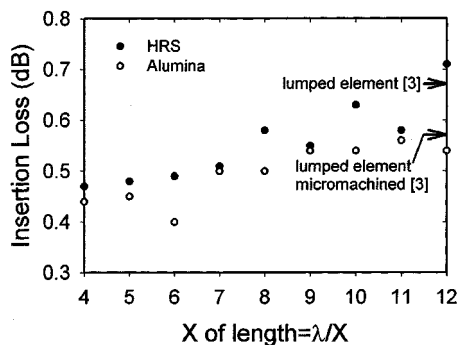

Fig. 3. Measured insertion loss of miniaturized Wilkinson power dividers fabricated on HRS and alumina.

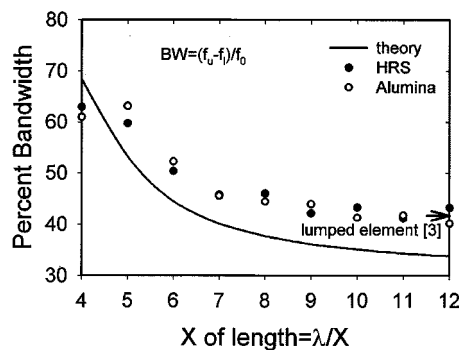

Fig. 4. Measured and theoretical bandwidth of miniaturized Wilkinson dividers fabricated on HRS and alumina.

[3]. It is seen that the reduced line length Wilkinson dividers presented here have an insertion loss that is comparable to the micromachined, lumped element design.

Typically, the measured reflection coefficient was less than -30 dB. The measured bandwidth, defined as the frequency band where $|S_{11}| < -15$ dB, is shown in Fig. 4 as a function of the transmission line length. Also shown is the theoretical bandwidth assuming perfect lumped elements (no parasitics and infinite Q) and lossless transmission lines. As expected, the theoretical bandwidth is less than the measured bandwidth, but the difference is small indicating well behaved circuit components. Also shown in Fig. 4 is the bandwidth of the lumped element Wilkinson divider [3]; it is seen that the miniaturized dividers presented here and the lumped element designs have similar bandwidth. It is also seen that for line lengths less than $\lambda/8$, the bandwidth does not decrease further. Lastly, the bandwidth is not dependent on the substrate.

However, the bandwidth of the power divider around the design frequency, f_0 , does not fully describe the circuit characteristics. Conventional Wilkinson dividers are periodic at all odd harmonics as shown in Fig. 5, but miniaturized circuits operate as a power divider only at f_0 . At higher frequencies, they perform like a low pass filter with the high frequency rejection increasing as the capacitive loading and the line impedance increases.

The measured isolation, $-20 \log |S_{23}|$, is better than 15 dB at the design frequency. However, the frequency of highest isolation increases as the circuit size is reduced; maximum isolation occurs approximately 1.5 GHz higher than f_0 for a $\lambda/12$ divider. This phenomenon has been reported and attributed to

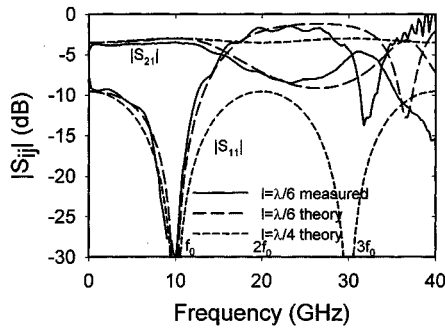

Fig. 5. Measured and theoretical characteristics of a miniaturized Wilkinson power divider.

an impedance mismatch when port 1 is terminated in a 50Ω load for the isolation measurement [4]–[6]. However, modeling with Advanced Design Systems [10] circuit simulation software shows that this assumption also causes a shift in S_{22} and S_{33} that is not seen in the reported or our results. Furthermore, the shift is not due to lossy transmission lines. Rather, it was determined that the cause of the frequency shift is due to a frequency independent, parasitic reactance that is associated with the TFR.

V. CONCLUSION

A miniaturized Wilkinson power divider employing capacitive loading and high impedance transmission lines has been presented. Results show that this approach can reduce circuit size by 74% without significantly increasing the insertion loss or decreasing the bandwidth. This is a significant reduction in area

that otherwise would be consumed by conventional Wilkinson power dividers.

ACKNOWLEDGMENT

The authors would like to thank N. Varaljay and B. Furfaro for fabricating the power dividers and E. McQuaid for preparing the CAD drawings.

REFERENCES

- [1] E. J. Wilkinson, "An N-way hybrid power dividers," *IEEE Trans. Microwave Theory Tech.*, vol. MTT-8, pp. 116–118, 1960.
- [2] T. Hirota, A. Minakawa, and M. Muraguchi, "Reduced-size branch-line and rat-race hybrids for uniplanar MMIC's," *IEEE Trans. Microwave Theory Tech.*, vol. MTT-38, pp. 270–275, March 1990.
- [3] L. Liang-Hung, P. Bhattacharya, L. P. B. Katehi, and G. E. Ponchak, "X-band and K-band lumped Wilkinson power dividers with a micro-machined technology," in *IEEE MTT-S Int. Microwave Symp. Dig.*, vol. 1, Boston, MA, June 11–16, 2000, pp. 287–290.
- [4] J. Ho and N. V. Shuley, "Wilkinson divider design provides reduced size," *Microwaves RF*, Oct. 1997.
- [5] T. Hirota and M. Muraguchi, "K-band frequency up-convertors using reduced-size couplers and dividers," in *GaAs IC Symp.*, Miami Beach, FL, 1992, pp. 53–56.
- [6] G. Carchon, K. Vaesen, S. Brebels, P. Pieters, W. De Raedt, and B. Nauwelaers, "Integrated Wilkinson power dividers in C-, Ku-, and Ka-band in multi-layer thin-film MCM-D," in *Eur. Microwave Conf.*, vol. 3, Paris, France, Oct. 3–5, 2000, pp. 171–174.
- [7] M. C. Scardelletti, "Power dividers and printed antennas utilizing coplanar transmission lines," thesis, Univ. South Florida, Tampa, Apr. 2, 1999.
- [8] J. Reed and G. J. Wheeler, "A method of analysis of a symmetrical four-port network," *IEEE Trans. Microwave Theory Tech.*, vol. MTT-4, pp. 246–252, Oct. 1956.
- [9] NIST Consortium User Guide, *Nat. Inst. Standards Technol.*, Mar. 1991.
- [10] *Advanced Design System, Version 1.5*: Agilent Technologies, 2001.