

# Bright Ideas: A wearable interactive “Inventometer” (brainwave-based idea display)

Steve Mann, Ryan Janzen, Hang Wu, Max Hao Lu, Nitin Guleria  
University of Toronto

**Abstract**—The light-bulb idea metaphor (a light bulb above someone’s head that appears or switches on when they think of an idea) is widespread in the literature and popular culture. But, to the best of our knowledge, nobody has ever built an actual device that implements this function. The “Inventometer” is a fun and playful wearable device that measures and displays epiphanometric data to a real light bulb, so its wearer and others in the environment are alerted to “aha! moments” (“eureka moments”), epiphanies, inventions, and idea formation in the brain/mind of the wearer. It senses brainwave signals indicative of epiphanies, and indicates to others a continuously varying epiphanometric quantity by adjusting the light output of the bulb. It uses simple machine learning on EEG (electroencephalograph) brainwave signals to automatically detect and quantify the novelty of ideas formed in the brain. Long exposure photographs — made while one or more Inventometer wearers walk around a room — result in a Phenomenal Augmented Reality (Augmented Reality of or pertaining to physical phenomena and phenomenology). In particular, these “epiphanographs”, over time, indicate what sorts of things in an environment tended to stimulate epiphanies and to what degree — epiphanogrammetry as a possible new field of study. Brain Games are designed so multiple people can compete using their minds much like people competing using their bodies (e.g. arm wrestling). The “brightest” people in a room become visible by way of their epiphanographs. But with their wearable display bulbs glowing brightly, they also serve as a distraction to each other, thus introducing a richly complex and competitive collective biofeedback gaming space. The device is meant to appeal to people of all ages, from children to university students, and thus forms a good teaching for making skills, science, and engineering (e.g. power electronics, 3D printing, etc.). It is also an ongoing research project.

## I. Introduction and Background

A number of fun and playful products have recently appeared on the market that sense and make visible human emotions. Examples include the prosthetic tail of Kyle Simmons which wags when the wearer is happy, to the Necomimi Brainwave Cat Ears from Japan, giving rise to the “Augmented Human Body”. See for example, “*How Being Quirky can Get Your Tech Startup Funding: Learn from Shota Ishiwatari*” (<http://www.bizpenguin.com>). Much of these recent developments build on the work of Picard who founded and introduced a new field of research called “Affective Computing” — computing that senses and expresses human emotion [1].

Throughout history we have often seen the ubiquitous light-bulb idea metaphor, e.g. a light bulb above someone’s head that appears or switches on when they think of an idea. But, to the best of our knowledge, nobody has ever built a real device that actually implements this function. So we present the “Inventometer”, a fun, playful, and cute wearable epiphanometric display device. This *idea idea* (meta-idea) is very simply stated: “turn on a real light bulb when someone’s thinking of an idea (and vary its brightness in proportion to the novelty of the idea)”. It presents some exciting research

on brainwave activity that can appeal to university students (including PhD students) working in machine learning and signal processing, as well as some simpler electrical wiring problems suitable for teaching at the high school or grade school electronics course levels. An important strength of the Inventometer is its universal appeal to people of all ages.

### A. Idea-Formation in the Brain

Generating a novel idea involves previously-unrelated mental concepts, which become connected or combined in the mind [2–4]. Neurological research to uncover the brain state changes during idea formation has divided the problem into cognitive processes: divergent thinking, artistic creativity, and insight [5–18]. Brain function during insight, creativity and divergent thinking can be signalled by factors including blood flow [18], electrical activity [5, 8, 10], and chemical signals such as dopamine [7]. Brain activity *before* idea-formation plays an important role [15, 16]. Dietrich et. al [19] summarize 63 articles attempting to detect these phenomena using electroencephalograph (EEG) and neuroimaging. We adapt this research, firstly to make it operate in real-time, and furthermore to function with a simple wearable user-interface rather than in a hospital setting, and, finally, to create playful augmentation to the human mind and body – “Brain Games” or “Mind Games”.

### B. Games and Human-Information Visualization

We wish to consider gaming in its broadest scope and definition, to include things like the augmented human mind and body, as well as to get at the fundamental root of what a game is. Collins English Dictionary (HarperCollins, 1979) defines a “game” as:

game: noun. 1. an amusement or pastime; diversion. Old English *gamen* "game, joy, fun, amusement," ... "joy, glee," ... "sport, merriment," ... "participation, communion," from Proto-Germanic \**ga-* collective prefix + \**mann* "person," giving a sense of "people together."

Serious Gaming [20–25] is a very relevant context to this work, since our design will use carefully-defined neurological measurements, and thus can reveal scientifically interesting data, in addition to offering a playful user-interface.

The Inventometer is a form of human-information-human interaction through brainwave-sensing computation. In thinking about whether to regard this as human-computer-human or human-information-human interaction, consider the fields of HCI (Human-Computer-Interaction) versus HII (Human-Information-Interaction), a field of research introduced by Gershon [26–28] in 1995 [28]. Gershon’s work is distinct from HCI (Human Computer Interaction) [29], in that its focus is

the information itself, i.e. its message content, rather than the physical hardware or the information media. The field of HII embodies many aspects of gaming, such as Storytelling, Spatial Narratives, and Augmented Reality [30–34], and other issues surrounding social justice, gender issues, privacy, etc. [35–39]. HII is an important design philosophy for looking at information processing [26]. HII is multisensory, affecting vision (light/illumination) as well as audition [34].

Games can also take the form of artistic interventions that playfully breach social norms [40]. In this paper, we build on the seminal work of Gershon, Kapralos, Bertozzi, Baecker, Fisher, Page, Solmi, and many others, with a simple human-information-human brainwave display device that is a form of *Tangible User Interface* [41].

### C. The light bulb as a symbol of inventions and ideas

In 1802, Sir Humphry Davy invented the world’s first incandescent light bulb, which provided inspiration for many others to improve upon over the next 75 years [42]. Then in the late 1870s, Thomas Edison made some improvements to the light bulb, and more importantly, created the electrical power distribution systems needed in order to support widespread use of electric light. The widespread adoption and distribution of electricity itself was mainly created for supplying electricity to light bulbs in particular (Other devices such as motors, radios, televisions, etc., became widely used much later, once electricity was already widely available.)

Edison noticed that light bulbs running on DC (Direct Current) darkened more near their positive terminal than their negative terminal. He created a number of experimental light bulbs with a metal plate inside the bulb, thus inventing the vacuum tube (diode), to illustrate what is now known as the “Edison Effect”, forming the basis for the new field of electronics, vacuum tubes, and hundreds of invention like radio, television, etc..

Professor Fleming (University College London) did consulting work for Edison Electric, and produced the “Fleming Valve” in 1904, a one-way valve for electricity, which he used as a detector for radio receivers. The Edison and Fleming devices were the first vacuum tubes — special light bulbs that switched on when electricity flowed one way, and off when it flowed the other way.

In 1906, Le de Forest, the “Father of Radio”, created the first successful three-element (triode) vacuum tube, a special light bulb with a control grid that could be used to amplify electrical signals. See Fig 1.

The work of Edison and others has brought the electric light bulb into such a degree of prominence, ubiquity, and iconography (Fig 2), that the light bulb itself has become the symbol of any kind of invention and idea, including inventions and ideas that have nothing to do with light bulbs or electricity. (See Fig 3.)

The word “intelligence” derives from the Latin verb “intelligere”, which means to “comprehend or perceive”. The light bulb has been associated with idea formation, and more broadly, intelligence. Thus it is a universally recognizable symbol of “brainpower”.

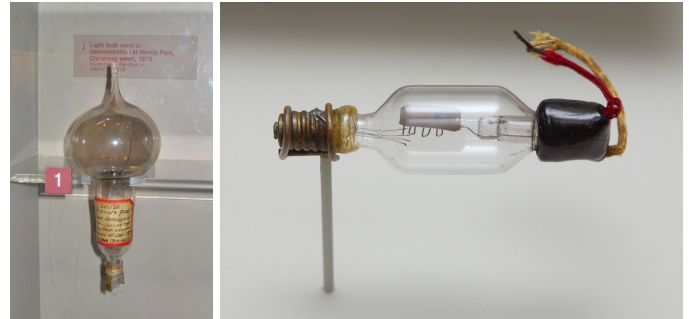

Fig. 1. Bright Ideas: (left) Edison’s Menlo Park light bulb, 1879. (right) Le de Forest’s light bulb was the first electronic amplifier. In addition to the Edison screw base on the left side of the light bulb, there are two additional electrodes on the right: a plate and a control grid, forming the world’s first 3-element vacuum tube. Pictures from Wikimedia Commons.



Fig. 2. Thomas Edison, TIME Magazine, “How One Powerful Idea ... INSIDE HIS IDEA FACTORY.”



Fig. 3. The light bulb — perhaps the greatest invention of all time — has become a universal symbol that represents ideas, revelation, creativity, and inventions, i.e. that represents idea formation in the brain. Images: Shutterstock, free clip-art, and physicsfromapicklejar.wordpress.com

#### D. On the use of the light bulb as an information display

The light bulb has been used not just for illumination, but also to convey information, e.g. indicator lamps that are affected by physical quantities. Early television displays also used lighting to convey the picture information (e.g. Nipkow Disk), and early motion picture film used lights and light sensors to record and play back sound. Other forms of lighting have also been invented for improved energy efficiency, lifespan, and response time, in applications like early motion picture film and video displays that required fast-responding light sources. The LED (Light Emitting Diode) for example was invented more than 100 years ago [43] and in modern times is commonly used as a replacement for incandescent indicator lights.

In the early 1970s, light sources (incandescent, LED, arc lamps, and high voltage electrical discharge) were used as AR (Augmented Reality) displays of physical quantities, e.g. to make visible the otherwise hidden world of radio waves, sound waves, and sightfields of surveillance cameras [44, 45]. In this way, a display of these otherwise hidden quantities was overlaid in perfect registration with the real world in which the quantities existed or could exist. See Fig 4.

#### E. Sousveillant Systems and “DoubleVision™”

The Inventometer is an example of open disclosure, because it is a form of inverse privacy (e.g. making thoughts public). It addresses the two common criticisms of wearable computing and associated wearable “cyborg” technologies, namely:

- that the wearable cameras and other sensors pay *too much* attention to others (e.g. issues of privacy); and
- a fear that the wearer might not be paying enough attention: “*Is he looking at me or reading his email?*”

The first of these has been extensively addressed in the literature under the topic of “sousveillance” (inverse surveillance), upon which hundreds of books, papers, and articles have been written [46]. The second of these criticisms is explored in this paper, as we attempt to playfully make visible a person’s thoughts, thus reversing privacy toward a sousveillant technology of public disclosure. The Inventometer, however, is not the first wearable display to do so. Such public disclosure has also been explored in previous work reported in the literature, such as Mann’s “DoubleVision™” system of wearable, mobile, and portable two-sided screens and displays. These double-sided displays had a screen facing the wearer, plus a second screen facing outward for others to see. This construct is a direct opposite of the commonly used 3M “privacy filters”! See Fig. 5.

Brainwave-controlled lighting is also known in the prior art, e.g. InteraXon’s “Bright Ideas” exhibit in which various lights on architectural landmarks have been controlled by brainwaves, as well as “Clara”, the brain-sensing, environmental augmenting, focus enhancing lamp. (<http://www.thingswemake.com/light-bulbs-lasers/>).

To the best of our knowledge, no prior work has been done specifically using a headworn light source that indicates idea formation, “epiphany”, or “brainpower”.

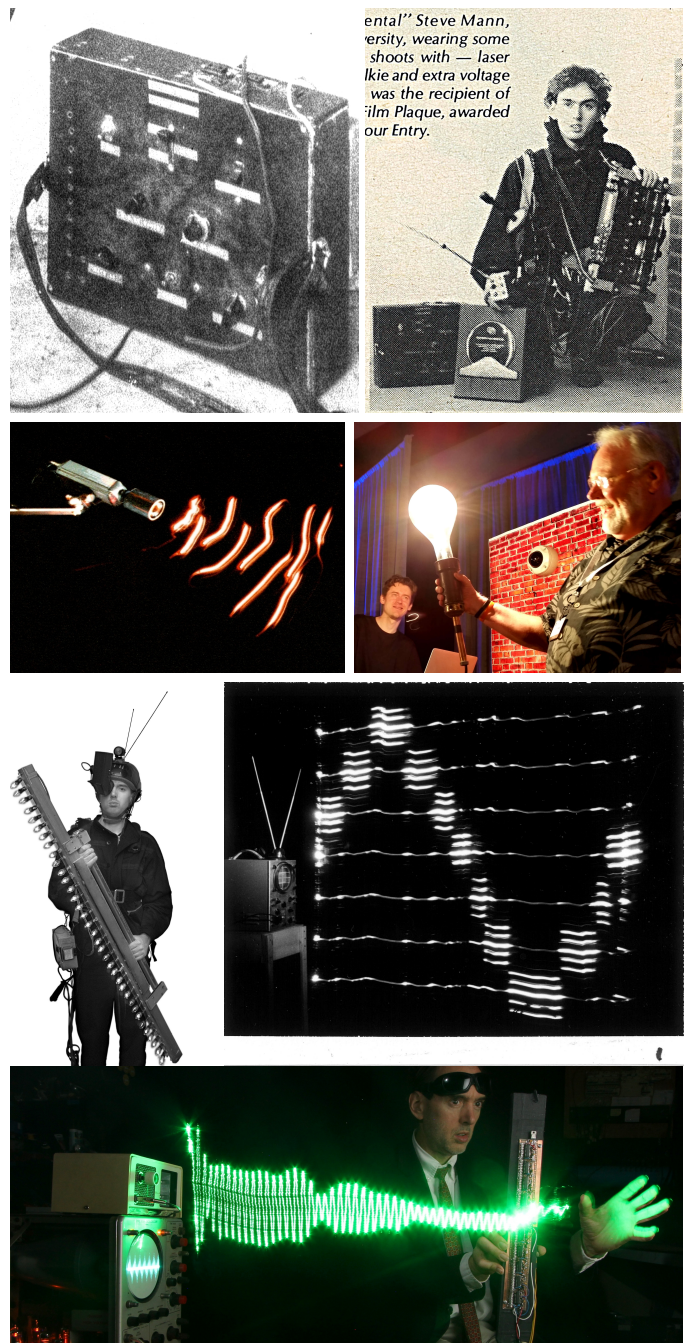

ental” Steve Mann, ersity, wearing some shoots with — laser lkie and extra voltage was the recipient of ilm Plaque, awarded our Entry.

Fig. 4. **Augmented Reality based on light bulbs:** Mann’s SWIM (Sequential Wave Imprinting Machine), and PHENOMENAmplifier, 1974, was a physical augmented reality system using sequentially illuminated light bulbs to display and overlay virtual waveforms and other content in perfect register with the real world. This allowed person to see the field of view of a surveillance camera, or see standing radio waves (as from a Doppler radar system), which was done using light bulbs, or, more recently, using modern LED technology (bottom image).



Fig. 5. **Inverse privacy: social and artistic experiments with two-sided computer screen to make what is normally, in wearable computing, private, something that is public.** Left and center: Plenary lecture plus week-long performance at Ars Electronica 1997. “DoubleVision™” two-way screen: one side faces the wearer; the other side faces others in the environment so they can see what the wearer sees, or a redacted version thereof. The double-sided display eliminated what was otherwise a socially obnoxious cyborg practice of being in one’s own world ignoring other people. While meeting someone, the wearable face-recognizer automatically did a background search and displayed that person’s web site. The person could see that the wearer was actually paying attention to them and not ignoring them by reading email or doing idle “web surfing”. Right: Mann’s exhibit at List Visual Arts Centre Oct9-Dec28, 1997.



Fig. 6. **Inventometer prototype with 64-electrode EEG “thinking cap”:** (left) with clear bulb in which the filament is visible (typical of light bulbs in the early 1900s); (right) with modern frosted light bulb, as has been more commonly used since the 1930s.

## II. The “Inventometer”

The Inventometer is a wearable epiphanometric information display that indicates a continuously varying degree of idea formation, or “brainpower”. It takes the form of a headworn light bulb. It works on EEG (brainwaves).

The most advanced brain mapping techniques are done using neuroimaging through fMRI, NMR and MRI, with the output of such brain scanning displayed with different colors indicating the brain activities of different regions [47]. A drawback of such techniques is that of expense and lack of portability or wearability.

Gamma waves have been associated with visual short-term memory capacity, intelligence, and consciousness, and are in the frequency range responsible for idea formation in the brain [48]. Recent research shows a correlation between cognitive decline and a decrease of EEG gamma activity, indicating a correlation between intelligence levels and gamma wave activities [49]. Thus we use gamma waves as a measure of ideation, intelligence, “brilliance”, or how “bright” a person is at any time, and display this information on a light bulb (clear or frosted). A first system prototype is shown in Fig 6, followed by an improved design in Fig 7.

The first prototype used a triac dimming circuit to control the brightness of the bulb, at 60 cycles per second AC (Alternating Current) line frequency (i.e. 120 chops per second,



Fig. 7. **Inventometer prototype based on the InteraXon Muse:** Two participants are seen here, one thinking of new ideas and inventions with a lab notebook, and the other sitting idle. We can see that the person toward the left side of the picture is the “brighter” person at this point in time.

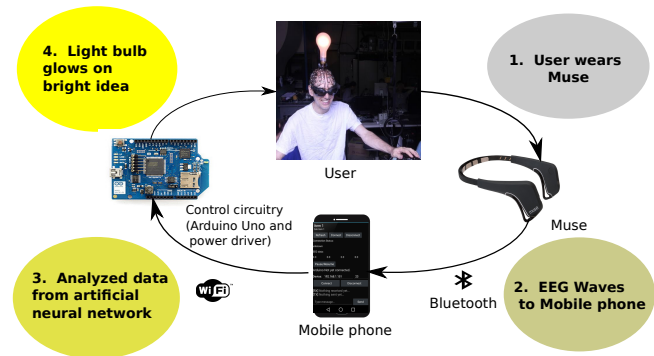

Fig. 8. **Process diagram of Inventometer prototype based on the InteraXon Muse.**

since there are two chops per cycle). This frequency was found to interfere with the brainwave sensing, which was done with the MindMesh 64-electrode brainwave sensor.

The improved design uses the InteraXon Muse, presently the world’s leading brainwave sensing device, together with a much higher switching frequency on the light bulb dimmer circuit. The improved dimmer circuit was operated on DC (Direct Current) at 12 volts rather than 120 volts AC. Additionally, the switching frequency on the dimmer was set to 40,000 cycles per second rather than 60 cycles per second, thus much further removed from the 25 to 100 cycles per second of the gamma waves being sensed. The operation is controlled by an Android smartphone app that uses wireless Bluetooth communication with the Muse. The result is displayed on a wearable light bulb that is controlled by way of a WiFi communications link to an Atmel AVR (Arduino) microcontroller, housed in a headworn device connected to a light bulb by way of a MOSFET (Metal Oxide Semiconductor Field Effect Transistor) driven by a gate driver chip connected to a PWM (Pulse Width Modulation) output of the microcontroller. This allows for continuously adjustable light output on either an incandescent (12 volt) or LED light bulb, without any noticeable interference of the brainwave sensing. The process is illustrated in Fig 8. and the

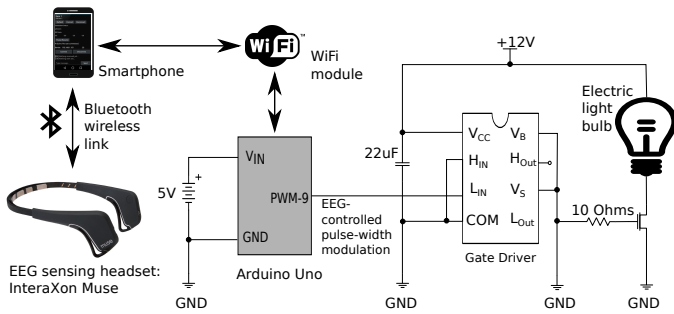

Fig. 9. **Hybrid block/wiring/schematic diagram of the Inventometer prototype based on the InteraXon Muse:** A smartphone app picks up signals from the Muse over Bluetooth and controls the brightness of a light bulb by way of our custom-made WiFi dimmer. This allows us to use a wide range of different kinds of light bulbs — incandescent or LED bulbs for example.

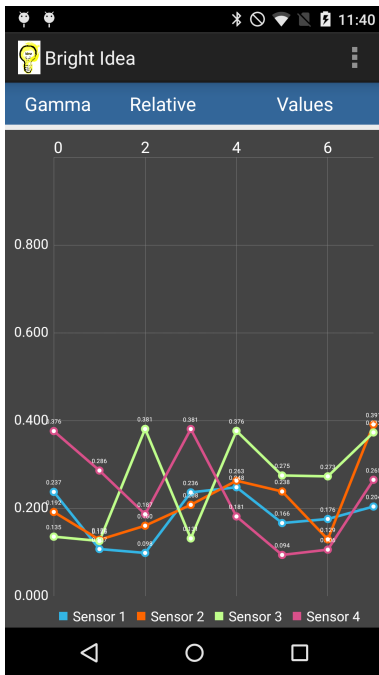

Fig. 11. **Screen capture of the inventometer app, which displays a monitor of a small number of monitoring signals separately from the internal machine learning algorithm.**

circuit diagram (a hybrid block/schematic/wiring diagram) is shown in Fig 9, which was housed in an enclosure as illustrated in Fig 10.

A screen capture of the inventometer app is shown in Fig 11.

### III. EEG Data Recording

The EEG signals were measured with the InteraXon Muse headband sensor. The Muse has its sensor contacts at the following four positions:

- TP9 (above left ear);
- FP1 (left part of forehead);
- FP2(right part of forehead);
- TP10 (above right ear).

In the Muse, EEG signals are oversampled and then down-sampled to yield an output sampling rate of 220 Hz with  $2\mu\text{V}$  (RMS) noise. Active noise suppression is achieved by the Muse with a feedback configuration using centrally positioned frontal sensors. The input range of the AC-coupled signal (low cutoff at 1 Hz) was 2 mV point to point [50].

Our system extracted 43 features from the EEG signals (activity at various frequency ranges), which were fed into an artificial neural network algorithm. The algorithm functioned as a classification system, trained to classify ideas as “novel” or “not novel” at the time of user response. The neural network was a two layer perceptron with 20 hidden nodes each.

### IV. Training the Artificial Neural Network

For initial training of the artificial neural network, we presented a group of participants with a cognition test and used the resulting 43 numerical features to form a machine learning training set. An “alternative uses” (AU) task [51] [52] was presented to the participants. Pictures of known common objects were shown to the participants, who were instructed to devise alternative uses for each object — uses which must be original and unconventional. The objects shown were chosen such that they are well-known common items for the electrical engineer test subjects, such as “light” or “soldering iron”. The images were presented on the screen, one at a time, and the participants were told to come up with a novel use for the item. This task was implemented as a modified version of an AU task from [4]. One key difference from [4] is that rather than merely attempting to detect the EEG responses, we attempt to *predict* the idea-generating activity using machine learning, based on the EEG response to control a 1-pixel display in real-time. To build the training set, we began with 6 participants (all men) aged between 23–26. Participants were electrical engineering students, having familiarity with electronics. The EEG system (InteraXon Muse) presented four channels of data corresponding to locations TP9, FP1, FP2, and TP10. These locations are receptive to activity in the prefrontal cortex, which is responsible for information processing and short term memory. The raw data was streamed via bluetooth and collected in a mobile application in which the alpha, beta, gamma, theta and delta power, both relative and absolute were used. Other input features were derived from the Muse’s internal software, including “mellow”, “eye blinking”, and “concentration”, and also used as inputs to the ANN. The user was directed to push a button on the mobile application to self-indicate whether they felt their idea was original or not, and this data was used as a ground-truth in the machine learning training. After completion of the training, the ANN system was used in conjunction with the existing setup. The system was further evaluated by additional data for verification, as illustrated in the *Results* section.

### V. Results

For verification, the method of Scaled Conjugated gradient backpropagation was used. Auto-correlation was used to test the desired output and the experimental output of the dataset provided.

The artificial neural network (ANN) produced a resulting confusion matrix (Figure 12), gradient descent patterns (Figures 13 and 14), and error statistics (Figures 15 and 16). The

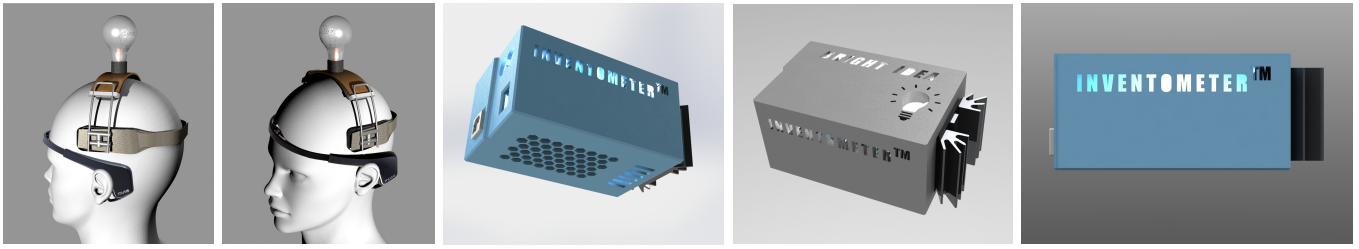

Fig. 10. 3D modelling of the assembly and physical enclosure for the Inventometer. The EEG sensor (InteraXon Muse) and mounting assembly for the light bulb are worn on the head, and a control box is hidden elsewhere on the body, to include the arduino microprocessor and power control unit.



Fig. 12. Artificial neural network (ANN) confusion matrix correlates EEG signals with a user's idea-generation.

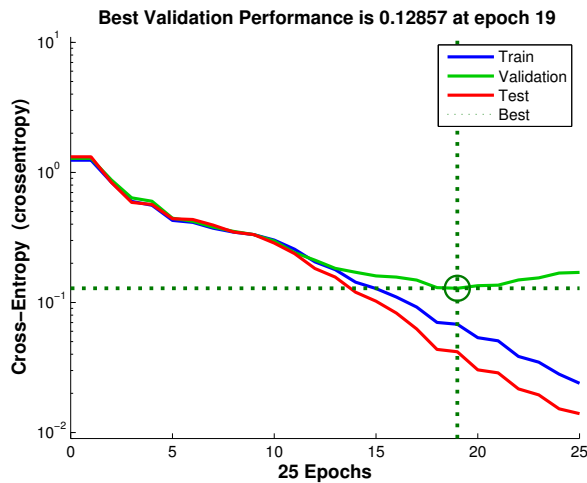

Fig. 13. Validation of the artificial neural network (ANN) performance, with cross-entropy.

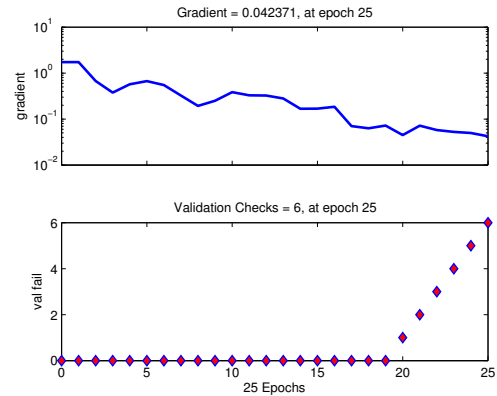

Fig. 14. Validation of the artificial neural network (ANN) performance, with gradient descent.

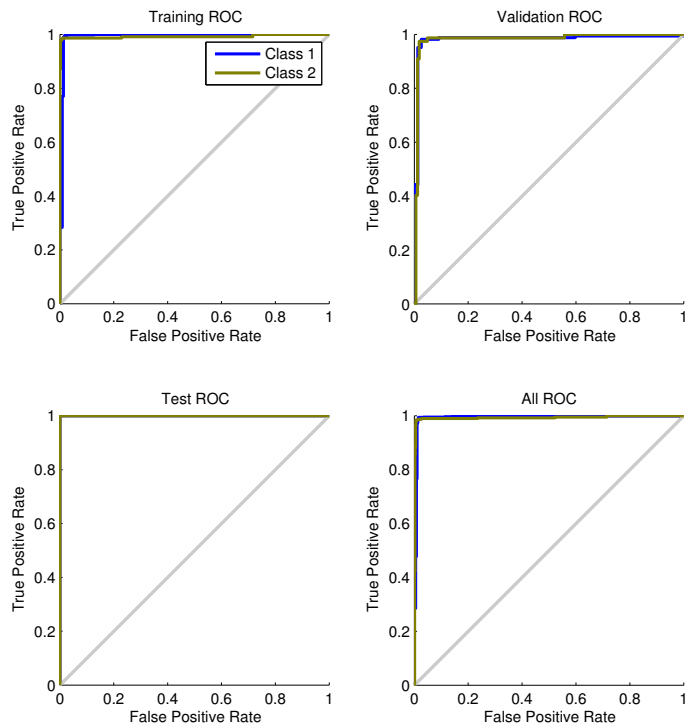

Fig. 15. Validation of the artificial neural network (ANN) performance, with gradient.

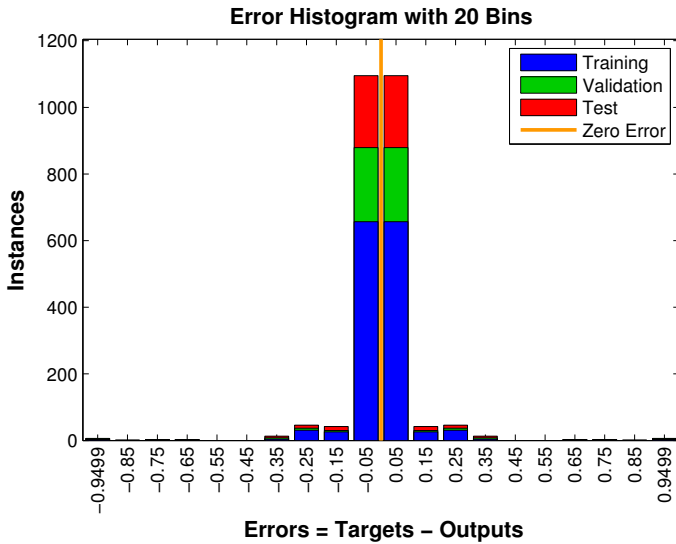

Fig. 16. Validation of the artificial neural network (ANN) performance: error histogram.

	Alpha alone	Beta alone	Gamma alone	Theta alone	Delta alone	Combined EEG data from ANN
Performance Values	0.183	0.133	0.0038	0.1071	0.000506	0.128
Epoch Values	32	41	74	55	88	25
Classification Accuracy	96.2%	95.6%	99.8%	99.3%	100%	98.9%
Gradient Values	0.067	0.111	0.0027	0.0277	0.00233	0.042

TABLE I. Results of different EEG bands for creative ideation

results in Table I indicate the significance of the delta signal in contribution towards the ideation process. The ANN model with delta signal as the sole input yields a 100

The neural network provides a correlation between EEG waves and creative ideation. Unlike previous studies that only studied the effects of creative ideation on alpha waves [51], we used a richer set of EEG wave data and furthermore made a classifier based on the user response with an artificial neural network (ANN). Since we are only measuring activity in the frontal and temporal lobes, we required more EEG wave spectral data than merely alpha waves to run the neural network to obtain a classifier for creative ideation. This allowed us to generalize and automatically determine the ideation process once it occurs and use the classifier for a light bulb.

## VI. Authintegrity: The Integrity of Authenticity

Additional inputs to the Muse measure parietal lobe activity [4] which is also linked with ideation, leading to new kinds of games and gaming. “Idea people”, *i.e.* authentic inventors, are in the state-of-flow when their Inventometer bulb is glowing, indicating a true love (rather than mere duty) of/to their profession. BrainGames/MindGames train for mind+body flow-state with biofeedback to reach simultaneously high alpha and beta brainwave states, while achieving simultaneous concentration, relaxation, and physical exertion while performing fitness or rehab exercises. See Fig 17.



Fig. 17. (left) Yoga in the state-of-flow (“Flowga” or “Hydroga”) exercises. In some embodiments brainwave-controlled water pumps are also used (hydraulic yoga). (right) Fitness rings driving game exercise and Nahum Gershon performing ankle exercise driving game at IEEE GEM2014 (Integral Kinesiology).

## VII. Conclusion

We presented the Inventometer, a wearable real-time neurosensing system which makes visible the process of ideation or invention. The system displays a cognitive epiphanometric quantity of each player or participant wearing the device, to allow a gaming environment, giving insight towards the “brightness” of a person’s ideas based on the brightness of a light bulb. Our epiphanometric system, based on a neural network (ANN), yielded a 98.9% correlation between target output and experimental output. Moreover, we have introduced epiphanography as a way of studying spaces, such as civic places, galleries, museums, and the like, as to their capacity to stimulate invention and creativity. This further advances the field of Phenomenal Augmented Reality.

## References

- [1] R. W. Picard and R. Picard, *Affective computing*. MIT press Cambridge, 1997, vol. 252.
- [2] L.-E. Datta, “Remote associates test as a predictor of creativity in engineers.” *Journal of Applied Psychology*, vol. 48, no. 3, p. 183, 1964.
- [3] A. Koestler, “The act of creation,” 1964.
- [4] M. Benedek, C. Mühlmann, E. Jauk, and A. C. Neubauer, “Assessment of divergent thinking by means of the subjective top-scoring method: Effects of the number of top-ideas and time-on-task on reliability and validity.” *Psychology of aesthetics, creativity, and the arts*, vol. 7, no. 4, p. 341, 2013.
- [5] R. H. Grabner, A. Fink, and A. C. Neubauer, “Brain correlates of self-rated originality of ideas: Evidence from event-related power and phase-locking changes in the eeg.” *Behavioral neuroscience*, vol. 121, no. 1, p. 224, 2007.
- [6] D. Q. Beversdorf, J. D. Hughes, B. A. Steinberg, L. D. Lewis, and K. M. Heilman, “Noradrenergic modulation of cognitive flexibility in problem solving,” *Neuroreport*, vol. 10, no. 13, pp. 2763–2767, 1999.
- [7] O. Blom, S. Cervenka, A. Karabanov, H. Forsberg, L. Farde, and F. Ullen, “Regional dopamine D2 receptor density and individual differences in psychometric creativity,” June 2008, poster session presented at the 14th Annual Meeting for the Organization for Human Brain Mapping, Melbourne, Australia.
- [8] O. Bazanova and L. Aftanas, “Individual measures of electroencephalogram alpha activity and non-verbal creativity,” *Neuroscience & behav. physiology*, vol. 38, no. 3, pp. 227–235, 2008.
- [9] E. M. Bowden and M. Jung-Beeman, “Aha! insight experience correlates with solution activation in the right hemisphere,” *Psychonomic Bulletin & Rev.*, vol. 10, no. 3, pp. 730–737, 2003.
- [10] S. Danko, N. Shemyakina, Z. V. Nagornova, and M. Starchenko, “Comparison of the effects of the subjective complexity and verbal creativity on eeg spectral power parameters,” *Human Physiology*, vol. 35, no. 3, pp. 381–383, 2009.
- [11] S. Danko, M. Starchenko, and N. Bechtereva, “Eeg local and spatial synchronization during a test on the insight strategy of

- solving creative verbal tasks,” *Human Physiology*, vol. 29, no. 4, pp. 502–504, 2003.
- [12] A. Fink, R. H. Grabner, M. Benedek, and A. C. Neubauer, “Divergent thinking training is related to frontal electroencephalogram alpha synchronization,” *European Journal of Neuroscience*, vol. 23, no. 8, pp. 2241–2246, 2006.
- [13] M. Jung-Beeman, E. M. Bowden, J. Haberman, J. L. Frymiare, S. Arambel-Liu, R. Greenblatt, P. J. Reber, and J. Kounios, “Neural activity when people solve verbal problems with insight,” *PLoS biology*, vol. 2, no. 4, pp. 500–510, 2004.
- [14] H. Haider and M. Rose, “How to investigate insight: A proposal,” *Methods*, vol. 42, no. 1, pp. 49–57, 2007.
- [15] J. Kounios, J. I. Fleck, D. L. Green, L. Payne, J. L. Stevenson, E. M. Bowden, and M. Jung-Beeman, “The origins of insight in resting-state brain activity,” *Neuropsychologia*, vol. 46, no. 1, pp. 281–291, 2008.
- [16] J. Kounios, J. L. Frymiare, E. M. Bowden, J. I. Fleck, K. Subramaniam, T. B. Parrish, and M. Jung-Beeman, “The prepared mind neural activity prior to problem presentation predicts subsequent solution by sudden insight,” *Psychological Science*, vol. 17, no. 10, pp. 882–890, 2006.
- [17] C. Martindale and N. Hasenfeld, “EEG differences as a function of creativity, stage of the creative process, and effort to be original,” *Biological psychol.*, vol. 6, no. 3, pp. 157–167, 1978.
- [18] N. Bekhtereva, S. Dan’ko, M. Starchenko, S. Pakhomov, and S. Medvedev, “Study of the brain organization of creativity: III. Brain activation assessed by the local cerebral blood flow and eeg,” *Human Physiology*, vol. 27, no. 4, pp. 390–397, 2001.
- [19] A. Dietrich and R. Kanso, “A review of eeg, erp, and neuroimaging studies of creativity and insight,” *Psychological bulletin*, vol. 136, no. 5, p. 822, 2010.
- [20] B. Kapralos, C. Johnston, K. Finney, and A. Dubrowski, “A serious game for training health care providers in interprofessional care of critically-ill and chronic care patients,” *Journal of Emerging Technologies in Web Intelligence*, vol. 3, no. 4, pp. 273–281, 2011.
- [21] C. C. Abt, *Serious games*. University Press of America, 1987.
- [22] D. Rojas, B. Kapralos, S. Cristancho, K. Collins, A. Hogue, C. Conati, and A. Dubrowski, “Developing effective serious games: the effect of background sound on visual fidelity perception with varying texture resolution.” in *MMVR*, 2012, pp. 386–392.
- [23] V. T. Pandeliev and R. M. Baecker, “A framework for the online evaluation of serious games,” in *Proceedings of the International Academic Conference on the Future of Game Design and Technology*. ACM, 2010, pp. 239–242.
- [24] F. Bellotti, B. Kapralos, K. Lee, P. Moreno-Ger, and R. Berta, “Assessment in and of serious games: an overview,” *Advances in Human-Computer Interaction*, vol. 2013, p. 1, 2013.
- [25] G. Baradoy, “A physiological feedback controlled exercise video game,” 2012.
- [26] N. Gershon, S. G. Eick, and S. Card, “Information visualization,” *interactions*, vol. 5, no. 2, pp. 9–15, 1998.
- [27] N. Gershon and S. G. Eick, “Information visualization,” *IEEE Computer Graphics and App’s*, vol. 17, no. 4, pp. 29–31, 1997.
- [28] W. Jones, P. Pirolli, S. K. Card, R. Fidel, N. Gershon, P. Morville, B. Nardi, and D. M. Russell, “It’s about the information stupid!: why we need a separate field of human-information interaction,” in *CHI’06 extended abstracts on Human factors in computing systems*. ACM, 2006, pp. 65–68.
- [29] R. M. Baecker and W. A. Buxton, “Readings in human-computer interaction,” *Morgan & Kaufman*, p. 670, 1987.
- [30] N. Gershon and W. Page, “What storytelling can do for information visualization,” *Communications of the ACM*, vol. 44, no. 8, pp. 31–37, 2001.
- [31] J. Parker, “Games are art: Video games as theatrical performance,” in *Games Innovation Conference (IGIC), 2013 IEEE International*. IEEE, 2013, pp. 203–208.
- [32] E. Bertozzi and S. Lee, “Not just fun and games: Digital play, gender and attitudes towards technology,” *Women’s Studies in Communication*, vol. 30, no. 2, pp. 179–204, 2007.
- [33] E. Bertozzi, “‘you play like a girl!’ cross-gender competition and the uneven playing field,” *Convergence: The International Journal of Research into New Media Tech.*, vol. 14, no. 4, pp. 473–487, 2008.
- [34] B. Kapralos, M. Jenkin, and E. Miliou, “Sonel mapping: acoustic modeling utilizing an acoustic version of photon mapping,” in *Haptic, Audio and Visual Environments and Their Applications, 2004. HAVE 2004. Proceedings. The 3rd IEEE International Workshop on*. IEEE, 2004, pp. 1–6.
- [35] K. Michael and M. Michael, “No limits to watching?” *Communications of the ACM*, vol. 56, no. 11, pp. 26–28, 2013.
- [36] S. Bronitt and K. Michael, “Human rights, regulation, and national security,” *IEEE Technol. Soc. Mag.*, vol. 31, no. 1, pp. 15–16, 2012.
- [37] K. Michael, G. Roussos, G. Q. Huang, R. Gadh, A. Chattopadhyay, S. Prabhu, and P. Chu, “Planetary-scale RFID services in an age of overveillance,” *Proceedings of the IEEE*, vol. 98, no. 9, pp. 1663–1671, 2010.
- [38] S. Mann, J. Nolan, and B. Wellman, “Sousveillance: Inventing and using wearable computing devices for data collection in surveillance environments.” *Surveillance & Society*, vol. 1, no. 3, pp. 331–355, 2003.
- [39] M. Costantino, “Federico Solmi and the phenomenology of the enemy,” in *Catalog for A Song of Tyranny, the Italian Cultural Institute of Madrid*, 2013.
- [40] E. Bertozzi, “The feeling of being hunted: Pleasures and potentialities of predation play,” *Games and Culture*, vol. 9, no. 6, pp. 429–441, 2014.
- [41] H. Ishii and B. Ullmer, “Tangible bits: towards seamless interfaces between people, bits and atoms,” in *Proc. ACM SIGCHI Conference on Human factors in computing systems*. ACM, 1997, pp. 234–241.
- [42] L. J. Davis, “Fleet fire: Thomas edison and the pioneers of the electric revolution,” 2003, ISBN 1-55970-655-4.
- [43] N. Zheludev, “The life and times of the led—a 100-year history,” *Nature Photonics*, vol. 1, no. 4, pp. 189–192, 2007.
- [44] “Steve mann,” *Campus Canada, ISSN 0823-4531, p55 Feb-Mar 1985, pp58-59 Apr-May 1986, p72 Sep-Oct 1986*.
- [45] S. Mann, “Wavelets and chirplets: Time–frequency perspectives, with applications,” in *Advances in Machine Vision, Strategies and Applications*, world scientific series in computer science - vol. 32 ed., P. Archibald, Ed. Singapore . New Jersey . London . Hong Kong: World Scientific, 1992.
- [46] V. Bakir, *Sousveillance, media and strategic political communication: Iraq, USA, UK*. Continuum International Publishing Group, 2010.
- [47] R. L. Savoy, “History and future directions of human brain mapping and functional neuroimaging,” *Acta psychologica*, vol. 107, no. 1, pp. 9–42, 2001.
- [48] A. W. Keizer, M. Verschoor, R. S. Verment, and B. Hommel, “The effect of gamma enhancing neurofeedback on the control of feature bindings and intelligence measures,” *International Journal of Psychophysiology*, vol. 75, no. 1, pp. 25–32, 2010.
- [49] S. Staufienbiel, A.-M. Brouwer, A. Keizer, and N. Van Wouwe, “Effect of beta and gamma neurofeedback on memory and intelligence in the elderly,” *Biological psychology*, vol. 95, pp. 74–85, 2014.
- [50] InteraXon, “Muse technical specification sheet,” InteraXon, Tech. Rep., 2014, <http://www.choosemuse.com>.
- [51] D. Schwab, M. Benedek, I. Papousek, E. M. Weiss, and A. Fink, “The time-course of eeg alpha power changes in creative ideation,” *Frontiers in human neuroscience*, vol. 8, 2014.
- [52] R. C. Wilson, J. Guilford, and P. R. Christensen, “The measurement of individual differences in originality.” *Psychological Bulletin*, vol. 50, no. 5, p. 362, 1953.