

# Unsupervised Classification of DNA Barcodes Species Using Multi-Library Wavelet Networks

Abdesselem Dakhli, Wajdi Bellil, Chokri Ben Amar

**Abstract**—DNA Barcode provides good sources of needed information to classify living species. The classification problem has to be supported with reliable methods and algorithms. To analyze species regions or entire genomes, it becomes necessary to use the similarity sequence methods. A large set of sequences can be simultaneously compared using Multiple Sequence Alignment which is known to be NP-complete. However, all the used methods are still computationally very expensive and require significant computational infrastructure. Our goal is to build predictive models that are highly accurate and interpretable. In fact, our method permits to avoid the complex problem of form and structure in different classes of organisms. The empirical data and their classification performances are compared with other methods. Evenly, in this study, we present our system which is consisted of three phases. The first one, is called transformation, is composed of three sub steps; Electron-Ion Interaction Pseudopotential (EIIP) for the codification of DNA Barcodes, Fourier Transform and Power Spectrum Signal Processing. Moreover, the second phase step is an approximation; it is empowered by the use of Multi Library Wavelet Neural Networks (MLWNN). Finally, the third one, is called the classification of DNA Barcodes, is realized by applying the algorithm of hierarchical classification.

**Keywords**—DNA Barcode, Electron-Ion Interaction Pseudopotential, Multi Library Wavelet Neural Networks.

## I. INTRODUCTION

DNA barcoding uses short sections of DNA to act as a unique identifier of species. This method of identification is fast, effective and an ideal complement for the morphological taxonomy..

Species classification with DNA Barcode sequences has been studied by several researchers. DNA Barcodes were proposed by Hebert et al., as a method to identify unknown specimen [1]. Short mitochondrial DNA (mtDNA) sequences (usually the 5' half of the *cox1* gene) are used to group unknown individuals with a priori defined taxonomic entities based on sequence similarity, deriving of species identification from DNA rather than from morphological characters.. Species classification with DNA Barcode sequences has been proven effective on different organisms [2]. In this work, the efficacy of supervised machine learning methods to classify species with DNA Barcode sequences is shown. The Weka software suite, which includes a collection of supervised classification methods, is adopted to address the task of DNA

Barcode analysis. Classifier families are tested on synthetic and empirical datasets belonging to the animal, fungus, and plant kingdoms. The performed experiments show a precise and effective species classification using DNA barcodes. The analysis of results on synthetic and real datasets shows that SVM and Naïve Bayes outperform, on average, the other considered classifiers. On the synthetic data, the supervised machine learning methods obtain superior classification performances compared to the traditional DNA Barcode classification methods. On the empirical data, the classification performances are at a comparable level with the other methods. M. Moftah et al. proposed an approach based on a morphological and DNA Barcodes approaches to solve the classification problem of Sharks in the Egyptian Mediterranean Waters [3]. This work provides an update on the composition of shark in the Egyptian Mediterranean waters of Alexandria, since the latest study was performed 30 years ago, DNA Barcodes were used in addition to classical taxonomical methodologies. Thus, 51 specimens were DNA barcoded for a 667 bp region of the mitochondrial COI gene. Although DNA Barcodes aim at developing species identification systems, some phylogenetic signals were apparent in the data. Lei C. et al proposed a method based on DNA Barcodes. They used DNA Barcodes, species and subspecies classification within genus *Carassius* [4]. Sandberg et al. proposed a method based on Bayesian approach. The mean accuracy obtained was 85% [5]. Francisca Z. et al. used Markov Model to classify proteins of microbes, eukaryotes and Archea. This classification followed an accuracy equal to 83.51%, 82.12% and 66.63% respectively for Eukaryota, Microbes and Archaea. This classification was presented in the form of phylogenetic groups [5], [6].

This paper is organized as follow: in Section II, we present an overview of the proposed approach. Section III is about the theory of Beta wavelet. This function will be used at Wavelet Network. Section IV deals with the simulation results of the proposed DNA Barcodes sequences classification method and Section V closes with a conclusion and discussion.

## II. METHODS

This paper presents a new approach of classification of DNA Barcodes sequences based on wavelet network using Multi Library Wavelet Neural Networks (MLWNN) to approximate  $f(x)$  of a DNA Barcodes sequences. This approach is divided into three stages: transformation of DNA, approximation of the input signal and classification of compact signature DNA Barcodes sequences using algorithm of hierarchical clustering.

Abdesselem Dakhli is with the National School of Engineers, University of Sfax, Tunisia. (corresponding author to provide phone: 28002213 e-mail: abdesselemdakhli@gmail.com).

Wajdi Bellil and Chokri Ben Amar are with the National School of Engineers, University of Sfax, Tunisia (e-mail: wajdi.bellil@ieec.org, Chokri.benamar@ieec.org).

### A. Transformation of DNA Barcodes Sequences

#### 1. DNA Barcodes Sequence Components

The proposed classification of species in class made according to DNA Barcodes sequence components. This sequence is formed by four basic nucleotides, adenine (A), guanine (G), cytosine (C) and thymine (T), where each organism is identified by its DNA sequence [7]-[9].

#### 2. Feature Extraction

Linear feature extraction can be viewed as finding a set of vectors which effectively represent the information content of an observation while reducing dimensionality [7], [9]. The method of indicator translates the data into numeric sequences format which can be used for DNA Barcodes signal spectrum analysis. This method uses EIIP sequence indicators where the energy of delocalized electrons in amino acids and nucleotides has been calculated as the Electron-ion interaction pseudopotential (EIIP) [5]. The EIIP values for the DNA nucleotides are given in Table I. For example, if  $x[n]=[A C C T A G G T T A C \dots]$ , then using the values from Table I,  $Xe[n]=[0.1260 0.1340 0.1340 0.1335 0.1260 0.0806 0.0806 0.1335 0.1335 0.1260 0.1340 \dots]$  (Table I).

TABLE I  
 ELECTRON ION INTERACTION PSEUDO POTENTIALS OF NUCLEOTIDES

Nucleotides	EIIP
A	0.1260
C	0.1340
G	0.0806
T	0.1335

#### 3. Fourier Transform and Power Spectrum Signal Processing

After the genomic data are converted into these EIIP sequence indicators, they can be manipulated with mathematical methods. The discrete Fourier Transform (DFT) is applied to each EIIP indicator sequence  $Xe(n)$ . The DFT of length  $N$  for input sequence  $Xe(n)$  is defined by:

$$f(x) = \sum_{n=0}^{N-1} X_e(n) e^{-j\pi n k / N}, k = 0, 1, 2, \dots, N-1 \quad (1)$$

It is easier to work with sequence Power Spectrum, rather than original discrete Fourier Transform. The Power Spectrum  $Se[k]$  for frequencies  $k= 0, 1, 2, \dots, N-1$  is defined as,

$$Se[k] = |f(x)|^2 \quad (2)$$

$Se [k]$  has been plotted (Fig. 1).

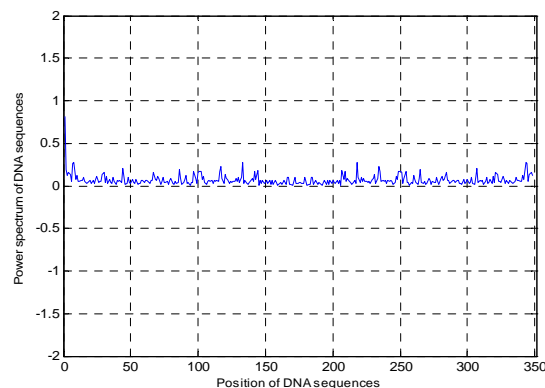

Fig. 1 Signal of a DNA Barcodes sequence using Power Spectrum

#### B. Approximation of DNA Barcodes Sequence Signal

DNA Barcodes sequence classification is an NP-complete problem. Indeed, when the alignment is beyond two sequences, the problem quickly becomes very complex because the space of alignment becomes very important. The recent advances of the sequences technology bring about a consequent number of DNA Barcodes sequences. We can be confronted to analyze some million sequences and a first stage for this analysis is to determine if there is a structure of the data in homogeneous groups according to a criterion to be determined. In this paper, a classifier is used to classify the DNA Barcodes sequences using Fourier Transform, Power Spectrum to process the signal and the application of Beta wavelet networks (BWN) as a classification model. This classifier solves the classification problems for DNA Barcodes sequences. Initially, the approach can bring the learning index defined by the 1D wavelet network to develop a compact signature of DNA Barcodes sequences. This signature is formed by the wavelet coefficients and used to match the DNA test with all the sequences in the training set. Then, for classification, the DNA test sequence is projected onto the wavelet networks of the learning DNA Barcodes sequences and new coefficients specific to this sequence are calculated (Fig. 2). Finally, we compare the coefficients of the learning DNA Barcodes sequences with the coefficients of the DNA test sequences by computing the Correlation Coefficient. In this step, we can apply the principle of hierarchical clustering to classify the characteristics of the DNA Barcodes sequences.

To approximate  $f(x)$  of a DNA Barcode sequence, the optimal wavelet is selected to obtain signal representation with minimal error rate. To solve the approximation problem, a library wavelet containing a family wavelet is used. This library is called Multi Library Wavelet Neural Network Model (MLWNN). In our approach, the second phase is to build the library wavelet and approximate the function  $f(x)$  of a DNA Barcode sequence.

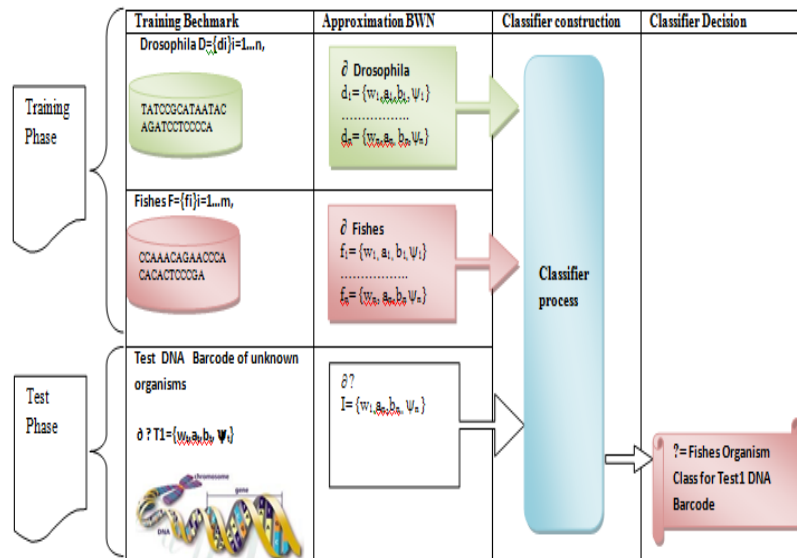

Fig. 2 DNA Barcodes sequence classification by BWN

### C. Learning Wavelet Network Using Multi Library Wavelet Neural Network (MLWNN)

In this section, we show how we can learn a wavelet network using library wavelet [16], [17].

#### 1. Proposed Learning Algorithm

**Step1.** Build a library of candidate wavelet to be choose to construct the wavelet network. This wavelet is used as activation function of network. This step includes the following items:

1. Choose the mother wavelet covering all the support of the signal of DNA Barcodes sequence to analyze.
2. Build a library that contains wavelets of the discrete wavelet transform using dyadic sampling.
3. Choose the lowest frequency wavelet of library. This wavelet allows a coarse approximation of the signal of DNA Barcodes sequence to be analyzed is introduced the first.
4. Set, as a stop learning condition, an error  $E_{min}$  between signal  $f$  and the output of the network or number  $i$  of the wavelet used for the learning or a number  $j$  of neurons in the hidden layer of the network.
5. Each time we choose the next wavelet of the library and iterate the following steps:

**Step2.** Compute the dual basis formed by the activation wavelets of the hidden layer of the network and the new selected wavelet.

**Step3.** The wavelet is used as an activation function of a new neuron in the hidden layer when it creates a basic orthogonal or bi-orthogonal with the  $(n-1)$  activation wavelet of the network; besides, it will update the  $(n-1)$  old weights of network.

**Step4.** We compute the output of the network by using the wavelet of hidden layers and the weights of the connection which are already calculated.

**Step5.** If the error  $E_{min}$  or the number of wavelets used  $i$  or

the number of neurons  $j$  are reached, then it's the end of learning, else another wavelet of the library is chosen and then we return to step2.

#### 2. Creation of Library Wavelet

To build the library of wavelets to join our wavelet network, a sampling on a dyadic grid of dilation and translation parameters is preceded [16], [17].

#### D. The Hierarchical Ascending Classification

This algorithm includes the following steps:

- Step1.** Start the input by preparing a list of DNA Barcodes sequences signatures and the number of classes to be obtained.
- Step2.** Create an empty matrix (Classes\_signature) which has to contain the groups of DNA Barcode sequences.
- Step3.** Start with each DNA Barcodes sequence signature in its own cluster. This procedure starts with  $n$  classes (each DNA Barcodes sequence signature forms a class containing only itself).
- Step4.** Compute the similarity between classes. The covariance matrix is used to measure the similarity between the DNA Barcode sequences signatures.
- Step5.** Research minimum similarity.
- Step6.** Find classes  $s1$  and  $s2$  with the minimum similarity to each other.
- Step7.** Merge clusters  $s1$  and  $s2$  and replace  $s1$  with the new class. Delete  $s2$  and recalculate all the similarities which have been affected by the merge.
- Step8.** Repeat steps (6) and (7) until the total number of classes becomes one.

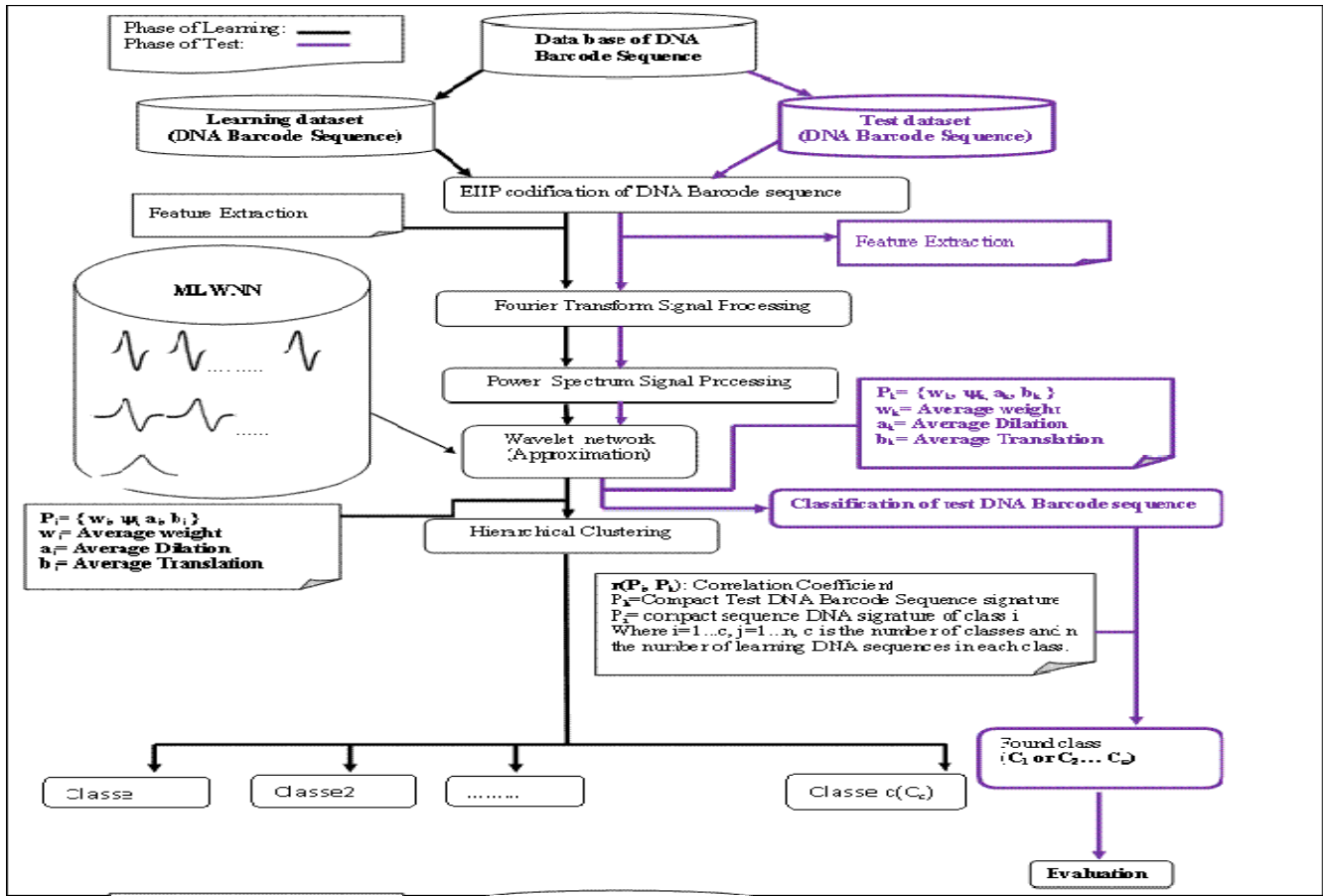

Fig. 3 Proposed approach

### III. THE BETA WAVELET FAMILY

The function beta is defined by  $\beta(x) = \beta(x_0, x_1, p, q(x))$  [5], [11], [12],  $x_0$  and  $x_1$  are real parameters.

$$\beta(x, p, q, x_0, x_1) = \begin{cases} \left(\frac{x-x_0}{x_c-x_0}\right)^p \left(\frac{x-x_1}{x_1-x_c}\right)^q & \text{if } x \in [x_0, x_1] \\ 0 & \text{otherwise} \end{cases} \quad (3)$$

We have proved, in [10]-[13], [15], that all the derivatives of Beta function  $\in L_2(\mathcal{R})$  and are of class  $C^\infty$  (Fig. 4). The general form of the nth derivative of Beta function is:

$$\psi_n(x) = \frac{d^n \beta(x)}{dx^n} = \left[ (-1)^n \frac{n!p}{(x-x_0)^{n+1}} + \frac{n!q}{(x_1-x)^{n+1}} \right] \beta(x) + P_n(x) P_1(x) \beta(x) + \sum_{i=1}^n C_n^i (-1)^n \frac{(n-i)p}{(x-x_0)^{n+1-i}} + \frac{(n-i)q}{(x_1-x)^{n+1-i}} \times P_1(x) \beta(x) \quad (4)$$

where:

$$P_1(x) = \frac{p}{x-x_0} - \frac{q}{x_1-x} \quad (5)$$

$$P_n(x) = (-1)^n \frac{n!p}{(x-x_0)^{n+1}} - \frac{n!q}{(x_1-x)^{n+1}} \quad (6)$$

If  $p = q$ , for all  $n \in \mathbb{N}$  and  $0 < n < p$ , the functions  $\Psi_n(x) = dn\beta(x)/dx^n$  are wavelets [11]-[15].

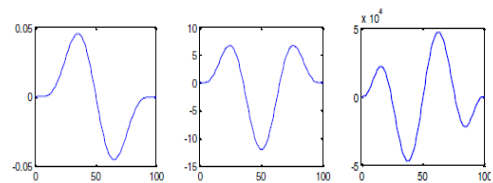

Fig. 4 First, second and third derivatives of Beta function

#### A. Wavelet Network

The combination of the wavelet transform and the artificial neuron networks defines the concept of the wavelet networks. This network uses the wavelet functions instead of the traditional sigmoid function as a transfer function of each neuron. It is composed of two layers (an input layer and a hidden layer) and it has the same structure as the architecture radial function. The salaries of the weighted outputs are added. Each neuron is connected to the other following layer. The Wavelet network (Fig. 5) is defined by pondering a set of wavelets dilated and translated from one mother wavelet with weight values to approximate a given signal  $f$ .

$$Y = \sum_{i=1}^{N_w} \omega(a, b) \psi\left(\frac{x-b}{a}\right) + \sum_{k=0}^{N_i} a_k x_k \quad (7)$$

where  $y$  is the output of the network,  $(x_1, x_2, \dots, x_{N_i})$  is the vector of the input and  $N_w$  is number of wavelets. There, it is often useful to consider, besides the decomposition of wavelets cleanly, that the output can have a component refine in relation to the variables of coefficients  $a_k$  ( $k = 0, 1, \dots, N_i$ ) (Fig. 5).

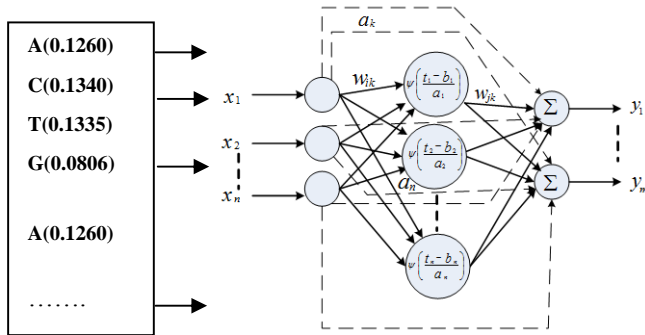

Fig. 5 Wavelet network

#### IV. RESULTS AND DISCUSSION

To evaluate the performance of our approach, we have developed different experiments, each consisting of a different subset of test data. The classification comparative analysis is performed using a selection of published empirical datasets and synthetic DNA Barcode datasets [18].

The eight selected empirical datasets summarized in Table II are the following; cypraeidae, drosophila, inga, bats, fishes, fungi and algae. The dataset comprises 2,008 DNA Barcode sequences with a length of 614 bases and from 613 species where 112 species are represented by at least four sequences.

In the learning steps and test, 262 DNA Barcode sequences were taken for each genome. These DNA strands are made to train and test our network wavelet Beta. During the test, the precision and the time of the classification were calculated and developed by our network wavelet beta. In this section, we present some experimental results of the DNA classification sequences by using the Fourier transform, Power Spectrum the Beta Wavelet Networks by approximating three 1-D functions.

TABLE II  
 DISTRIBUTION OF AVAILABLE DATA INTO TRAINING AND TESTING SET OF DNA BARCODE SEQUENCE

Classes	Total	Training	Test
Cypraeidae	211	100	111
Drosophila	19	10	9
Inga	56	40	16
Bats	82	52	30
Fishes	82	52	30
Birds	150	90	60
Fungi	8	4	4
Algae	5	3	2
Total	613	351	262

First, during the approximation phase, our model tried to decompose the input signal for every sequence and then tried to reconstruct the input signal. The estimation of the performance of this phase was measured by the Mean Square Error (MSE). Table IV shows that the Mean Square Error (MSE) obtained is low (0.000145) and the run-time increases relatively with the size of the DNA Barcode sequence. The results show that the size of the DNA Barcode sequence increases the time of the training phase. Time depends on the size of a DNA sequence. When the size is equal to 1,128, the training time is equal to 10,223 seconds. To solve the approximation problem, we use the library wavelet which contains a family wavelet. This library is called Multi Library Wavelet Neural Network Model (MLWNN). The library contains 6 mother wavelets (Beta1, Beta2, Beta3, Mexican4 hat, Polywog5 and Slog6) (Table III).

TABLE III  
 SELECTED MOTHER WAVELETS AND NORMALIZED ROOT MEAN SQUARE ERROR (NRMSE)

DNA Barcode sequence	Seq. length	Beta1 wavelet	Beta2 wavelet	Beta3 wavelet	Mexhat4 wavelet	Slog5 wavelet	Polywog6 wavelet	NSRMSE
Cypraeidae (S1)	614	1	1	4	1	2	1	0.42124
Drosophila (S2)	663	2	3	2	1	1	1	0.55623
Inga (S3)	1.838	2	1	2	3	2	0	0.61122
Bats (S4)	659	2	2	1	2	0	3	0.45256
Fishes (S5)	419	1	2	1	2	2	2	0.62356
Birds(S6)	255	3	1	1	3	0	2	0.52457
Fungi(S7)	510	2	2	1	1	2	2	0.78596
Algae (S8)	1.128	2	2	1	4	0	1	0.65471

TABLE IV  
 MSE OF APPROXIMATION OF THE SIGNAL FOR DNA

DNA sequence for each Class	Seq. length	MSE (Mean Square Error)	Training Time (sec)
Cypraeidae	614	0.002854	69.607
Drosophila	663	0.002471	46.297
Inga	1,838	0.003041	63.279
Bats	659	0.001092	45.145
Fishes	419	0.005841	36.08
Birds	255	0.004587	22.25
Fungi	510	0.005874	38.333
Algae	1,128	0.000145	10.223

TABLE V  
CLASSIFICATION RATE OF OUR APPROACH FOR NCBI ORGANELLE DATABASE

Actual Classes	Predicted Classes								Classification Rate (%)
	1	2	3	4	5	6	7	8	
1 Cypraeidae	108	0	0	0	1	2	0	0	97.297
2 Drosophila	0	9	0	0	0	0	0	0	100
3 Inga	0	0	16	0	1	0	0	0	94.118
4 Bats	0	0	0	28	1	1	0	0	93.333
5 Fishes	0	0	0	0	29	1	0	0	96.667
6 Birds	0	0	0	1	1	57	1	0	95
7 Fungi	0	0	0	0	0	0	4	0	100
8 Algae	0	0	0	0	0	0	0	2	100
User Accuracy (Recall)%	100	100	100	96.55	87.87	93.4	80	100	
Overall accuracy %									96.198

TABLE VI  
ACCURACIES FOR THE EMPIRICAL DATASETS [%]

Dataset of DNA Barcode sequences	SVM	Jrip	J48	Naïve Bayes	Wavelet Neural Network (WNN)
Cypraeidae	94.32	86.93	91.76	93.18	100
Drosophila	98.28	94.83	91.38	96.55	100
Inga	89.83	88.14	88.14	91.53	100
Bats	100	100.00	98.15	100.00	96.553
Fishes	95.50	90.09	92.79	97.30	87.879
Birds	98.42	84.86	91.80	94.32	93.443
Fungi	80.00	50.00	60.00	70.00	80
Algae	100.00	60.00	60.00	100.00	100
average accuracy	94.54	81.85	84.25	92.86	94.73

The results show that the WNN can achieve very good prediction accuracy. Results of our approach (Wavelet Neural Network (WNN)) tested on empirical datasets show that accuracy outperforms the other techniques in terms of percentage of the correct species identification. Tables IV-VI show the distribution of the good classifications by class as well as the rate of global classification for all the DNA Barcode sequences of the validation phase. These results are obtained using network wavelets. After showing the results in this table, we can realize the following interpretations;

- The DNA Barcode sequences of class “Drosophila”, “Cypraeidae” and “Inga” are perfectly classified (100%) (Table VI)
- We can indicate some errors between, for example, the class of “Fishes” and that of “Birds” and between the class of “Bats” and that of “Fishes”. This error can be due to the similarity between DNA Barcode sequences. These similarities explain the hereditary aspects between the organisms. Afterward, we can biologically explain and interpret the evolution of the living organisms through history. Results of comparison show that the WNN model performs better than the classical one in the context of training run time and classification rate.
- The analysis of the results on synthetic and real datasets shows that SVM and our WNN approach outperform to some degree the other considered classifiers. Our method provides an interpretable human classification model. The Rule-based methods have slightly inferior classification performances, but they deliver the species specific positions

and nucleotide assignments. On the synthetic data, the supervised machine learning methods obtain superior classification performances compared to the traditional DNA Barcode classification methods.

## V. CONCLUSIONS

In this paper, we have used a new method of training called Library Wavelet Neural Network Model (MLWNN). It is used to construct Wavelet Neural Network (WNN). The WNN is used to approximate function  $f(x)$  of a DNA Barcode sequence signal. Our method depends on Electron-ion interaction pseudopotential (EIIP) codification, Fourier Transform and Power Spectrum, processing the DNA Barcode sequence signal. Applying this hierarchical classification enables us to group the similar DNA sequences according to some criteria. This classification aims at distributing  $n$  DNA Barcode sequences characterized by  $p$  variables  $X_1, X_2, \dots, X_p$  in a number  $m$  of subgroups which are homogeneous as much as possible where every group is well differentiated from the others.

In our approach, we used the Correlation Coefficient or Pearson Correlation Coefficient which is applied to measure the association between two vectors of DNA Barcode sequences signal. Our approach helps to classify organisms into different categories and classes which have significant biological knowledge and can justify the evolution and identification of unknown organisms. Moreover, it studies mutual relations between organisms. This classification can, to a great extent, explain the study of the living organisms. Simulation results are demonstrated to validate the generalization ability and efficiency of the proposed Wavelet Neural Network Model. These results were realized thanks to many capacities listed as;

- The capacity of Library Wavelet Neural Network Model (MLWNN) to construct Wavelet Neural Network (WNN)
- The capacity of EIIP sequence indicators Codification, Fourier Transform and Power Spectrum to process the signal of DNA sequences,
- The capacity of the networks of wavelets in approximate of the functions real gives a complex.

- Finally, a powerful tool and a pipeline to perform species classification are provided to the DNA Barcodes community.

#### ACKNOWLEDGMENT

We would like to acknowledge the financial support, under the form of grant, from the General Direction of Scientific Research (DGRST), Tunisia.

#### REFERENCES

- [1] P. D. N. Hebert, A. Cywinska, S. L. Ball and JR. DeWaard, "Biological identifications through DNA barcodes". *Proc R Soc*, 2003, pp. 313-321.
- [2] E. Weitschek, G. Fison and G. Felici, "Supervised DNA Barcodes species classification: analysis, comparisons and results", *BioData Mining*, vol. 7:4 2014, pp.2-18.
- [3] M. Moftah, S. H. Abdel Aziz, S. Elramah and A. Favereaux, "Classification of Sharks in the Egyptian Mediterranean Waters Using Morphological and DNA Barcodes Approaches", *PLoS ONE*, vol. 6, 2011, pp. 1-7.
- [4] Ch. Lei, Ch. Yu-Mei, C. Ding-Cheng and S. Xiao-Wen, "DNA Barcodes and species and subspecies classification within genus *Carassius*", *Zoological Research*, vol.33, 2012, pp. 463-472.
- [5] R. Sandberg, G. Winberg, CI Bränden, A. Kaske, I ErnbergI and J. Cöster, "Capturing Whole - Genome characteristics in short sequences using a naive Bayesian classifier", *Genome Res*, vol.11, 2001, pp. 1404-1409.
- [6] F. Zanoguera and M. Francesco, "Protein classification into domains of life using Markov chain models", *Proceedings of the 2004 IEEE Computational Systems Bioinformatics Conference*, 2004, 0-7695-2194-0/04
- [7] C. Wu, M. Berry, Y.-S Fung and J. McLarty, "Neural Networks for Molecular Sequence Classification", *Proc Int Conf Intell Syst Mol Biol.*, 1993, pp. 429-437.
- [8] S. Kumar Subramanian and D. N, "Artificial Neural Network Based Method for Classification of Gene Expression Data of Human Diseases along with Privacy Preserving", *International Journal of Computers & Technology*, vol.4, 2013, pp. 722-730.
- [9] S. bai Arniker and H. Keung Kwan, "Advanced Numerical Representation of DNA Sequences", *International Conference on Bioscience, Biochemistry and Bioinformatics IPCBEE*, vol.31, 2012, pp.1-5.
- [10] W. Bellil, C. Ben Amar and M. Adel Alimi, "Beta Wavelet Based Image Compression", *International Conference on Signal, System and Design, SSD03*, Tunisia, vol.1, 2003, pp.77-82.
- [11] W. Bellil, C. Ben Amar and Mohamed AA: Synthesis of wavelet filters using wavelet neural networks", *Transactions on Engineering, Computation and Technology* 2006, vol.13, pp. 108-111.
- [12] C. Ben Amar, M. Zied and M. Adel Alimi, "Beta wavelets. Synthesis and application to lossy image compression", *Journal of Advances in Engineering Software*, Elsevier Edition, vol.36, 2005, pp. 459 – 474.
- [13] W. Bellil, C. Ben Amar and M. Adel Alimi, "Synthesis of wavelet filters using wavelet neural networks", *Transactions on Engineering, Computation and Technology*, vol.13, 2006, pp. 108-111.
- [14] C. Ben Amar, W. Bellil and M. Adel Alimi, "Beta Function and its Derivatives: A New Wavelet Family", *Transactions on Systems, Signals and Devices*, vol.1, 2006, pp. 275-293.
- [15] W. Bellil, C. Ben Amar and M. Adel Alimi, "Beta wavelets networks for function approximation", *International Conference on Adaptative and Natural Computing Algorithms, ICANNGA05*, Coimbra Portugal, Springer Wien NewYork, 2005, pp. 18-21.
- [16] M. Zaied, O. Jemai and C. Ben Amar, "Training of the Beta wavelet networks by the frames theory: Application to face recognition", *ieeexplore.ieee.org*, *Image Processing Theory, Tools & Applications*, 2008, 978-1-4244-3322-3/08/.
- [17] M. Zaied, C. Ben Amar and M. Adel Alimi, "Beta wavelet Networks for Face recognition", *Journal of decision systems*, vol.14, 2005, pp.109-122.
- [18] [dmb.asi.cnr.it/supbarcodes.php](http://dmb.asi.cnr.it/supbarcodes.php).

**Abdesselem dakhli** continued these academic studies to FSEG Sfax, Tunisia. He obtained his teacher's certificate in data processing applied to management in June 2001. He continued his degree of Masters in ISIMG of Gabes, Tunisia in 2008. In 2010, he received his Master degree in Information system in the same Institute. In August 2005 he was assigned to the ISG Gabes, Tunisia. Currently, he is a teacher at ISG. In 2012, now he prepares a Phd thesis of bioinformatic in ENIS. Abdesselem dakhli he also participated in one international conference. His areas of research are: Tomography, Bioinformatics.

**Wajdi Bellil** received the B.S. degree in Electrical Engineering from the National Engineering School of Sfax (ENIS) in 2000, the M.S. and PhD degrees in Electrical Engineering from the National Engineering School of Sfax (ENIS), in 2003 and 2009, respectively. He spent five years at the ISET Gafsa, Tunisia, as a technologic assistant and researcher before joining the faculty of Science of Gafsa, Tunisia, as Assistant. He joined the Higher Institute of Applied Sciences and Technology, Gafsa University, where he is currently an assistant professor in the Department of computer science. He was a member of the REsearch Group on Intelligent Machines (REGIM). He is a junior member of IEEE.

**Chokri Ben Amar** received the B.S. degree in Electrical Engineering from the National Engineering School of Sfax (ENIS) in 1989, the M.S. and PhD degrees in Computer Engineering from the National Institute of Applied Sciences in Lyon, France, in 1990 and 1994, respectively. He spent one year at the University of "Haute Savoie" (France) as a teaching assistant and researcher before joining the higher School of Sciences and Techniques of Tunis as Assistant Professor in 1995. In 1999, he joined the Sfax University (USS), where he is currently a professor in the Department of Electrical Engineering of the National Engineering School of Sfax (ENIS). He is a senior member of IEEE, and the chair of the IEEE SPS Tunisia Chapter since 2009. He was the chair of the IEEE NGNS'2011 (IEEE Third International Conference on Next Generation Networks and Services) and the Workshop on Intelligent Machines.