



Design and Construction of a Remote Monitoring and Control System for a Dehumidifier combined with a Heating Module

Young-Woo Seo¹, Won-Jae Lee¹, Young-Joo Kim¹, Sun-Ok Chung^{1*},
Young-Kyun Jang², Seung-Ho Jang², Im-Sung Bae³,

College of Agriculture and Life Sciences, Chungnam National University, Republic of Korea¹,
Shinan Green-Tech Co., Ltd, Suncheon, Cheonnam 58027, Republic of Korea², Green Control System Co., Ltd, Gwangju 61027, Republic of Korea³

Introduction

- ❖ Temperature/humidity in greenhouse
- ❖ Automatic or manual control in set value
- ❖ Real-time, visible at a glance
- ❖ Low error rate, responsible

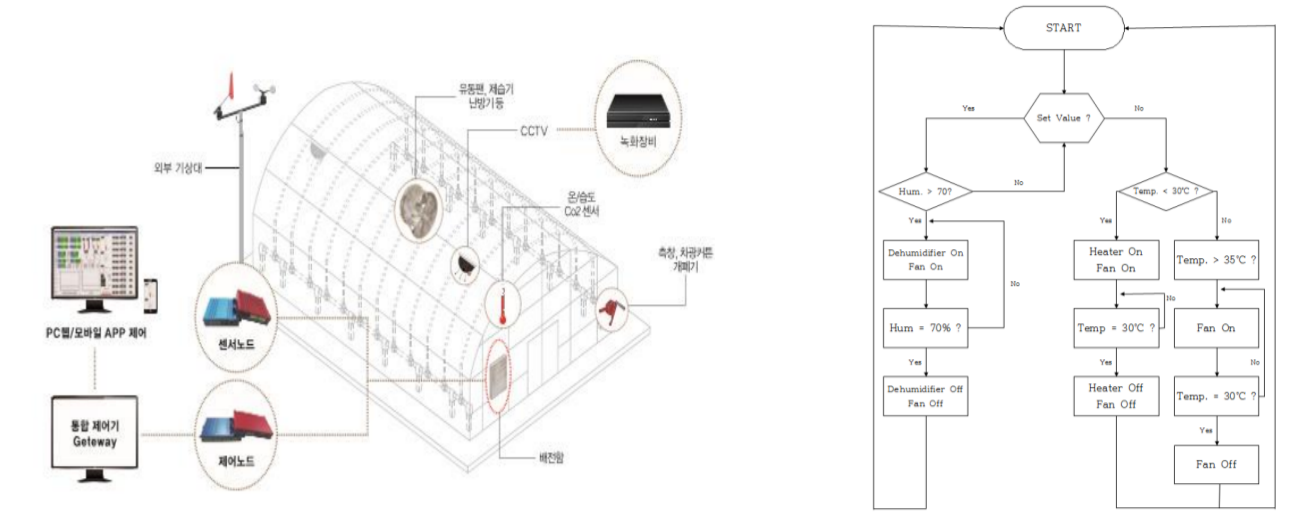

Materials and Methods

❖ System block diagram

- Sensor node : Sensors + ZigBee
- Control node : ATmega128 + ZigBee + Relay

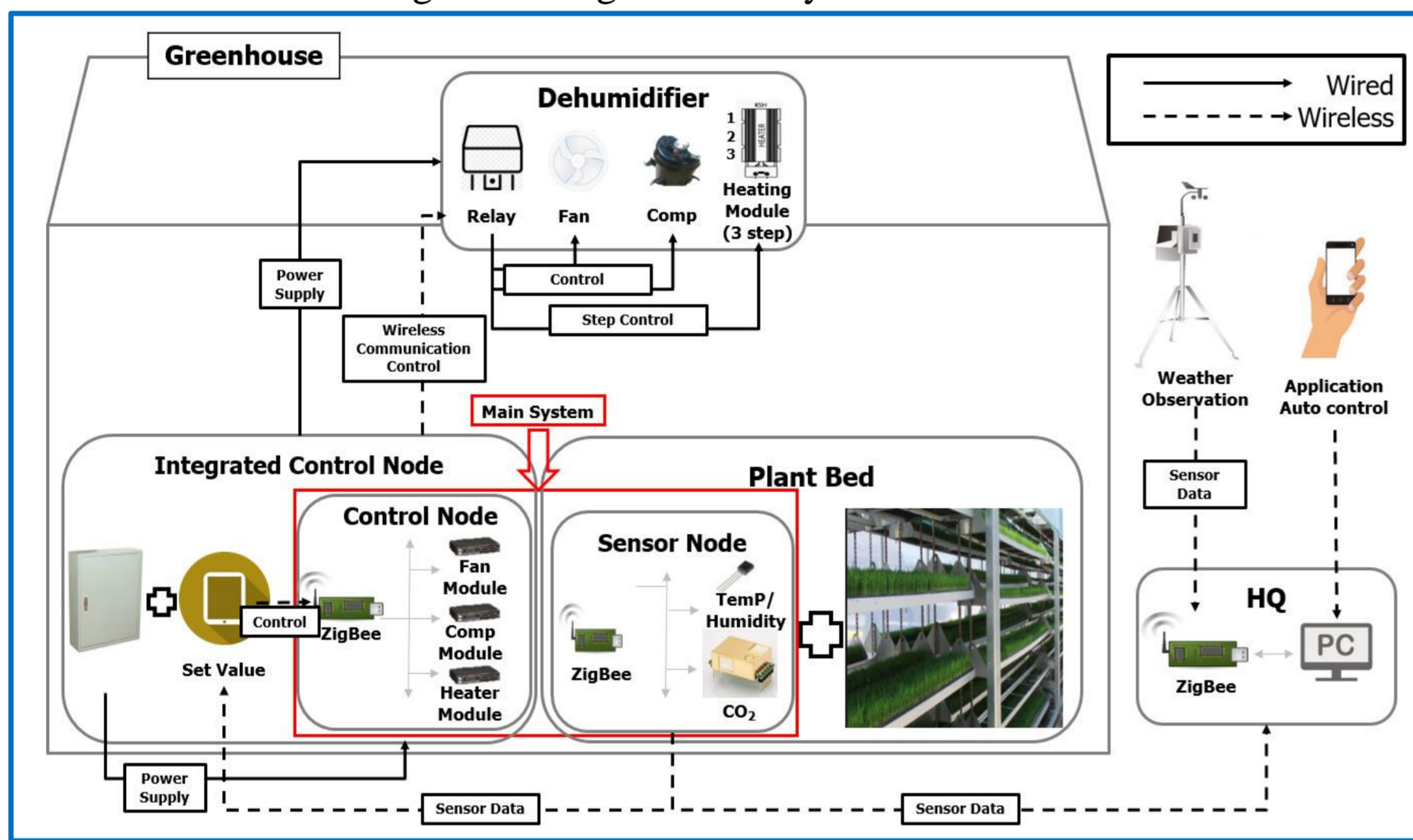

Block diagram of monitoring and control system

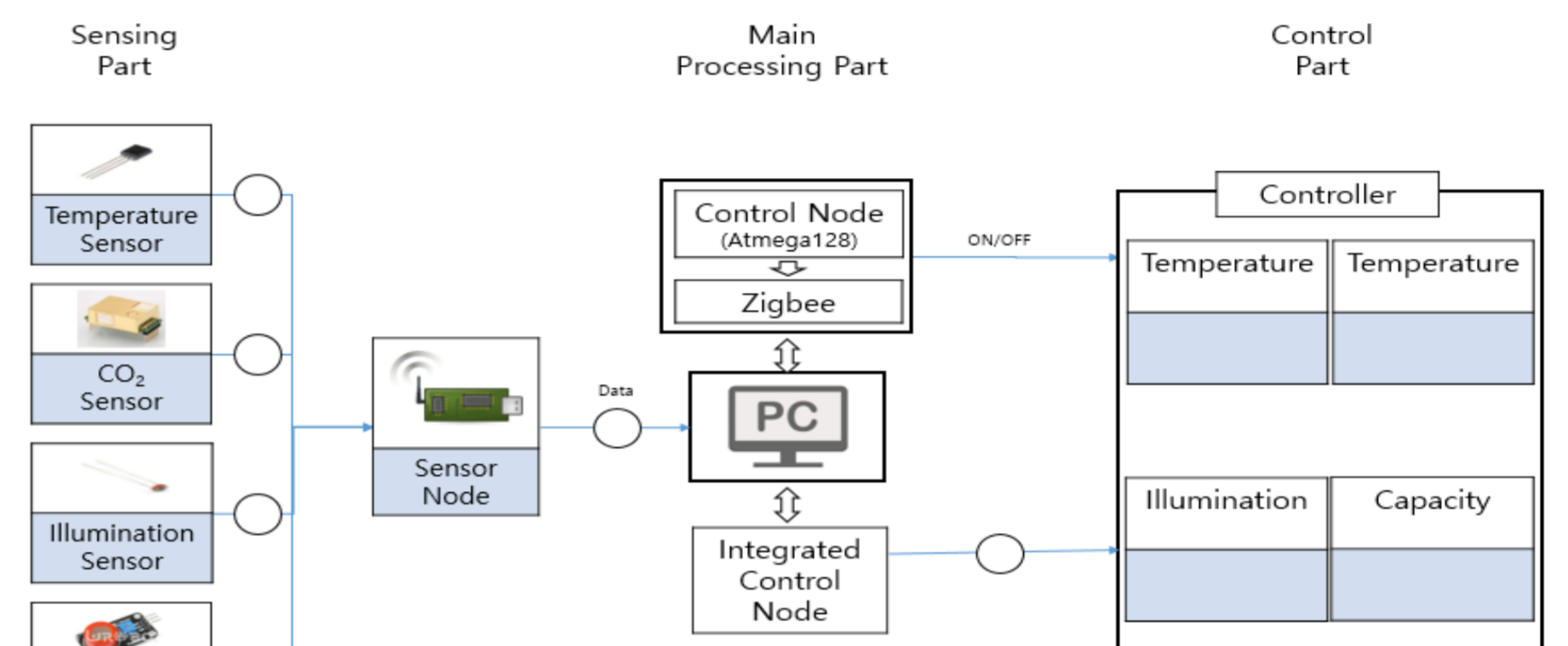

Schematic of the main control system

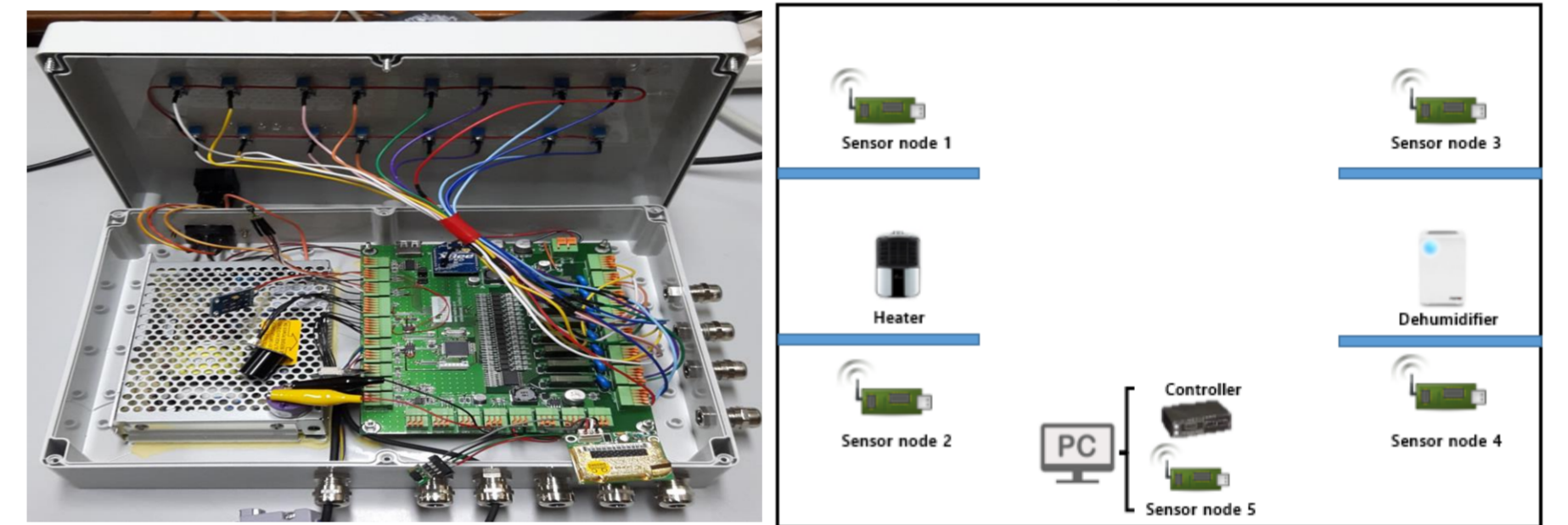

Developed sensor and control interface module(Left), Location of the sensor nodes used in the experiment(Right)

Results and discussion

❖ Control Systems

- Receive data in real-time
- Auto/manual control
- Save files in .xls or .txt format

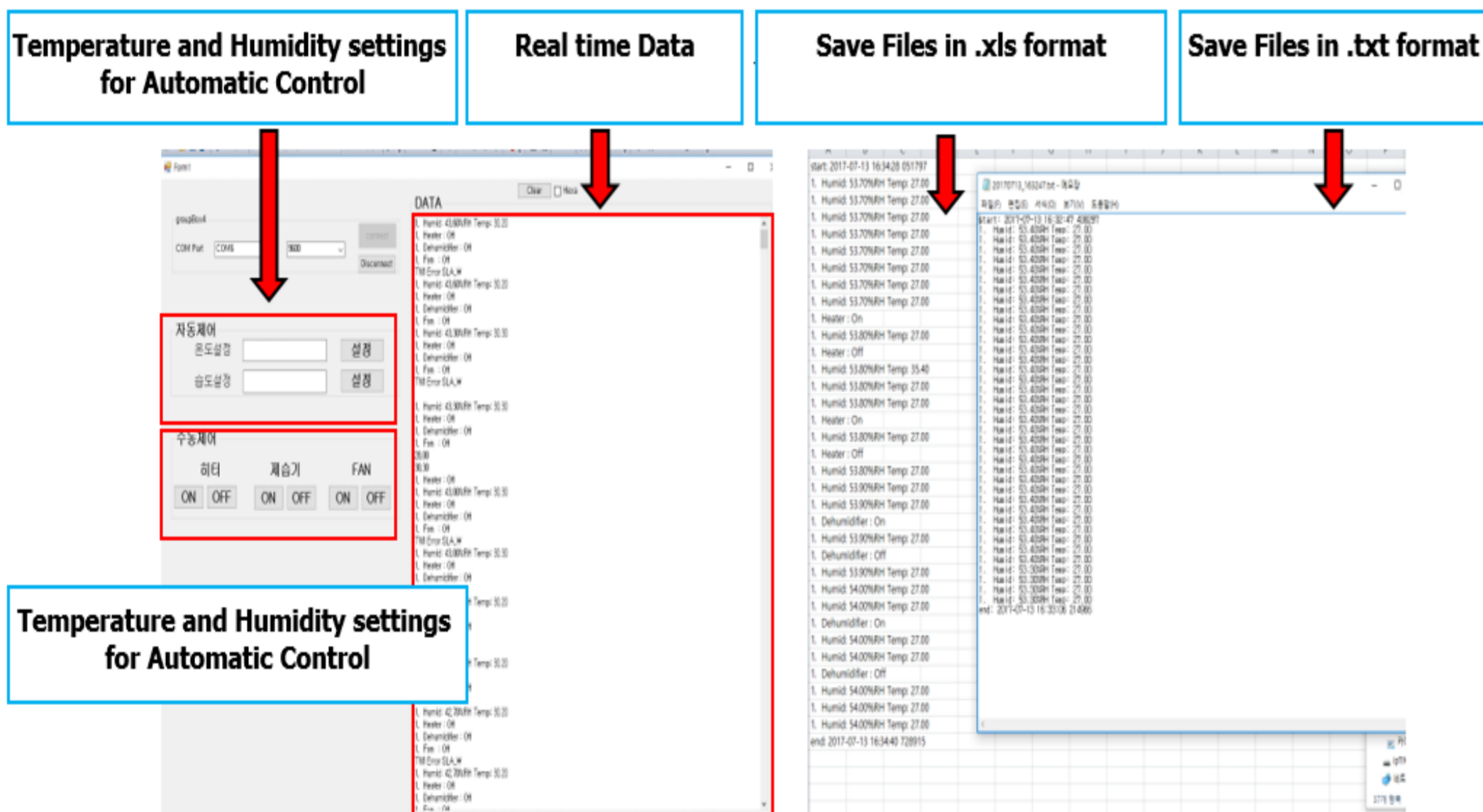

Developed sensor and control interface monitoring program

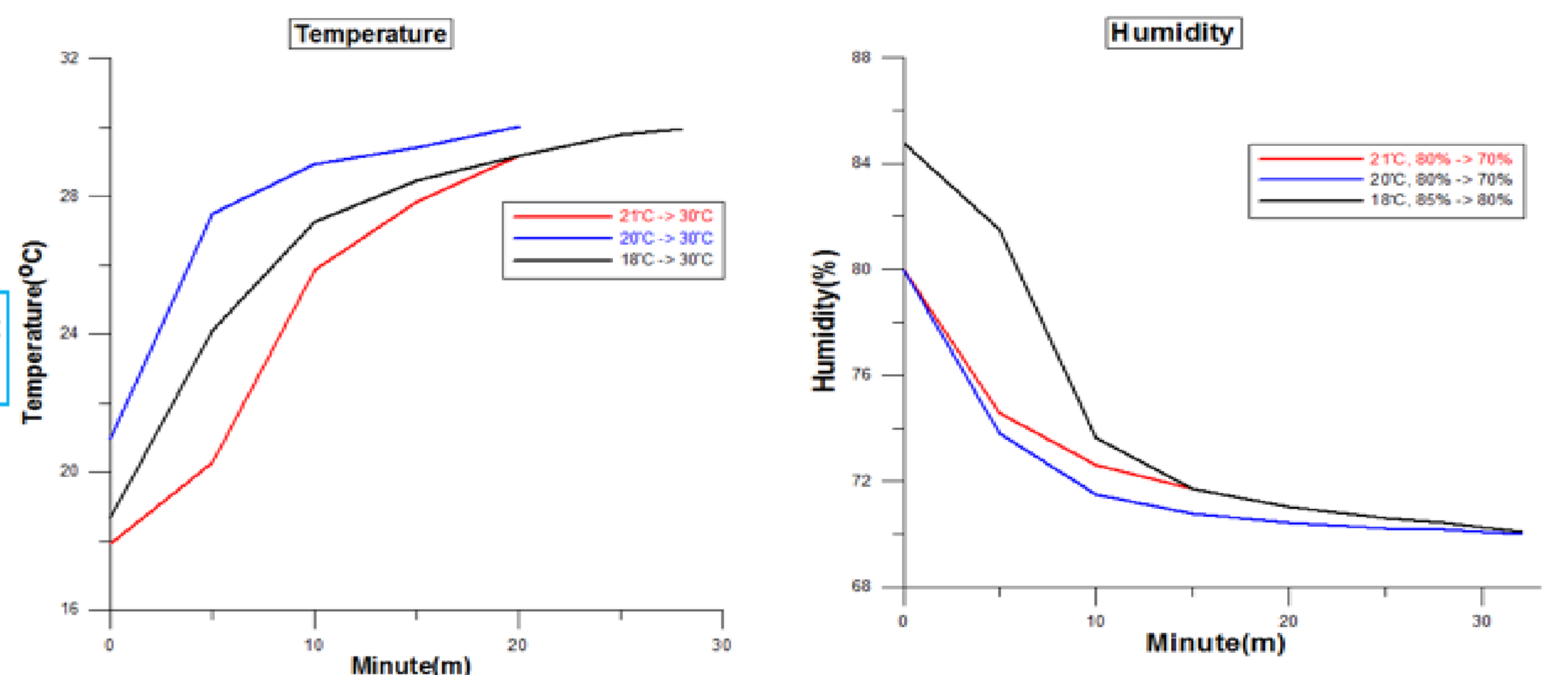

Temperature(left) and humidity(right) control experiment graph

Average and standard deviation on temperature control experiment

Target Temperature	Average and Standard deviation	
30 °C	29.9±0.28 °C	30.51±1.05 °C

Average and standard deviation on humidity control experiment

Target Humidity	Average and Standard deviation	
70%	70.7±0.99%	69.9±1.25%

Conclusions

❖ Review of the results

- Average error = 0.28 °C in the target temperature
- Average error = 0.99% in the target humidity

❖ Improvement factors

- More and various sensors input in need
- Further test under crop growing conditions
- Control algorithm

Acknowledgement

This work was supported by Korea Institute of Planning and Evaluation for Technology in Food, Agriculture, Forestry and Fisheries(IPET) through Advanced Production Technology Development Program, funded by Ministry of Agriculture, Food and Rural Affairs(MAFRA)(Project No. 316082-03)